

# *The Free Energy Secrets of Cold Electricity*

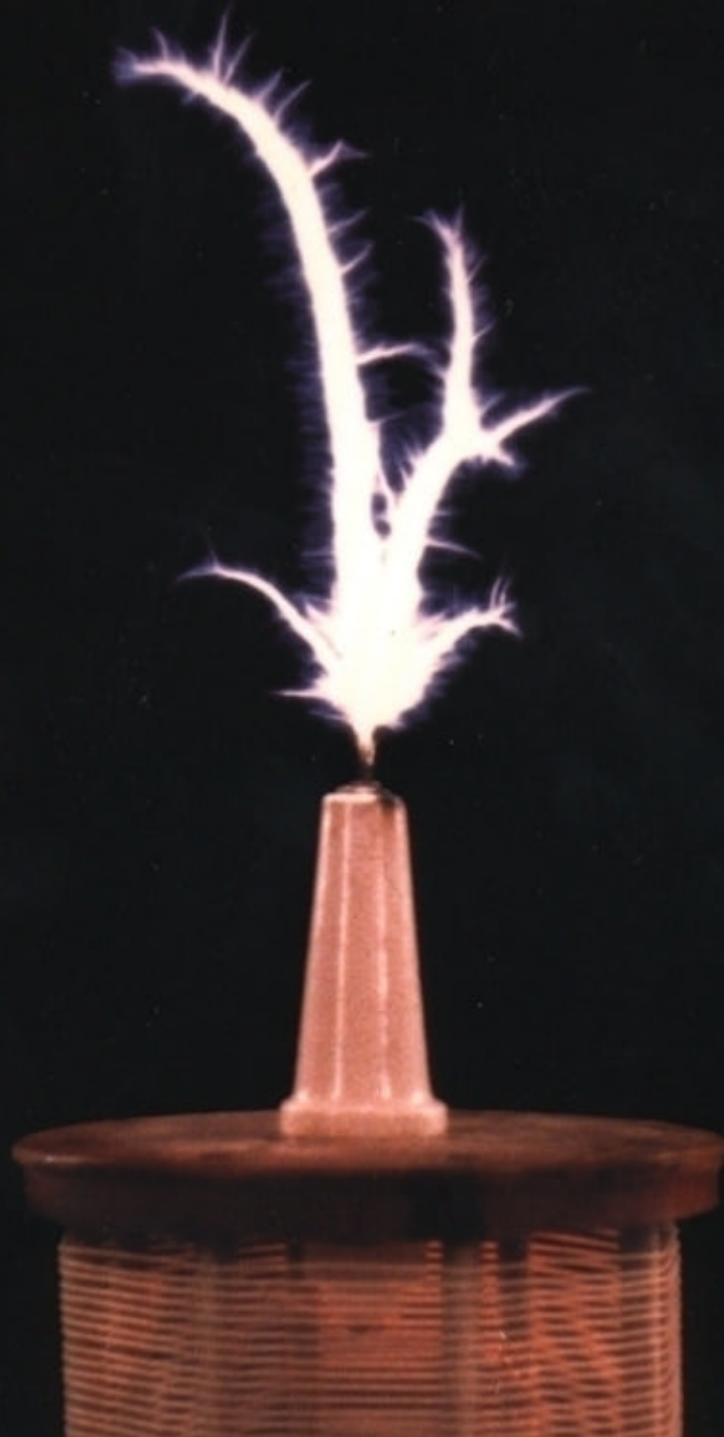

# *The Free Energy Secrets of Cold Electricity*

Peter A. Lindemann, D.Sc.

Published By:  
Clear Tech, Inc. PO Box  
37 Metaline Falls, WA  
99153 (509) 446-2353

## TABLE OF CONTENTS

<b><i>List of Illustrations</i></b>	vii
<b><i>Preface</i></b>	ix
<b><i>Chapter 1</i></b>	
The Edwin Gray Mystery	1
Edwin Vincent Gray (1923-1989)	13
<b><i>Chapter 2</i></b>	
The Rosetta Stone	15
<b><i>Chapter 3</i></b>	
Verifying Tesla's Secret	31
<b><i>Chapter 4</i></b>	
Decoding Gray's Patents	47
<b>Appendix I</b>	
Three US. Patents by Edwin V. Gray	65
<b>Appendix II</b>	
Three U.S. Patents by Dr. Nikola Tesla	101
<b>Appendix III</b>	
Two Articles by Dr. Peter Lindemann	117
<b>References</b>	129

## LIST OF ILLUSTRATIONS

1 First Article from <i>The National Tattler</i>	xii
2 Edwin Gray Demonstrating His Circuit	2
3 Tom Valentine With "Cold" Light Bulb in Water	2
4 Second Article from <i>The National Tattler</i>	3
5 Article from <i>Probe The Unknown</i>	4
6 Letter from EVGray Enterprises	5
7 Cover of <i>NewsReal</i> Magazine	6
8 Article from <i>NewsReal</i> Magazine	7
9 Gray's Motor Patent Cover Sheet	8
10 Gray's Motor Patent Schematic	8
11 Gray's Circuit Patent Cover Sheet	9
12 Gray's Conversion Tube Patent Cover Sheet	9
13 Gray's Circuit "Schematic"	10
14 <i>Secrets of Cold War Technology: Project HAARP and Beyond</i>	12
15 Tesla's Mechanical Circuit Controller	32
16 Magnetically Quenched Spark-Gap	34
17 Hot Air Quenched Spark Gap	34
18 Tesla's Electrical Transformer	35
19 Tesla's Transformer Patent Diagram	36
20 Tesla's Magnifying Transmitter Illustration	37
21 Tesla's Magnifying Transmitter as Described in the Patent	39
22 Illustration from a Tesla Lecture, February 1893	40
23 Close-Up of "Method of Conversion"	41
24 Radiant Energy Discharge	42
25 Summary of the Electro-Radiant Event	44
26 Gray's Circuit "Schematic" and the Simplified Gray's Circuit "Schematic"	46
27 Common Features of Tesla's Magnifying Transmitter and Gray's Cold Electricity Circuit	49
28 Gray's Circuit "Schematic"	50
29 Gray's Conversion Tube Diagram	53
30 Edwin Gray and His # 6 Motor Prototype	54
31 Edwin Gray and Fritz Lens in 1973	55
32 Gray's Inductive Load	56
33 Tesla's Radiant Energy Method	57
34 Probable Schematic for Gray's Cold Electricity Circuit	58
35 Paul Baumann's Testatika Machine	61
36 Testatika Machine Lighting a Light Bulb	61

## PREFACE

Ever since I first encountered the work of Edwin Gray more than a quarter of a century ago, I have attempted to unravel the mystery of how he produced free energy. Only recently has sufficient information emerged to enable me to finally piece all of the clues together and reach a definitive conclusion. In "The Free Energy Secrets of Cold Electricity," I share this 27-year odyssey and the knowledge that has evolved along the way.

Edwin Gray discovered that the discharge of a high voltage capacitor could be shocked into releasing a huge, radiant, electrostatic burst. This energy spike was produced by his circuitry and captured in a special device Mr. Gray called his "conversion element switching tube." The non-shocking, cold form of energy that came out of this conversion tube powered all of his demonstrations, appliances, and motors, as well as recharged his batteries. Mr. Gray referred to this process as "splitting the positive." These claims were incomprehensible; however, because Gray did not reveal anything about the conditions the circuit had to create in order to produce the effect. This was the mystery.

It wasn't until I correlated Gray's clues with an analysis by Gerry Vassilatos, published in 1996, detailing Nikola Tesla's experimental work in the late 1880's, that the picture started coming into focus. These experiments resulted in the discovery of what Tesla called "radiant energy" and led to the development of his Magnifying Transmitter. This material was the clue that unraveled the Gray mystery.

An exhaustive comparison between Gray's "cold electricity" systems and Tesla's "radiant energy" systems leads to the reasonable conclusion that these two discoveries are one and the same. Finally, in this light, Gray's circuit schematics are "corrected" and all of the omissions are filled in. It is my belief that enough information is provided herein to enable anyone interested in the pursuit of free energy to reproduce these "cold electricity" effects with relatively simple equipment. It is my hope that thousands of engineers and experimenters will now begin looking into reproducing this, the "Mother Lode" of Free Energy effects.

Many people have given invaluable assistance and counsel during this journey of mine, and I wish to acknowledge them with profound thanks. To Tom Valentine, for aggressively pursuing the story of Ed Gray, for his excellent and accurate reporting, for his tremendously revealing photographs, and for his exceptional generosity in making his entire archive available to me. None of this would have happened without his contribution.

To Eric Dollard for being the first one in this generation to truly understand Nikola Tesla's work with impulse currents, and for repeatedly demonstrating this knowledge with experimental apparatus. To Gerry Vassilatos for so brilliantly articulating and accurately conveying the story of Tesla's discoveries, and to David Hatcher Childress, the publisher of Gerry's book, for giving me unusually wide latitude in quoting large sections of this book.

To the late Bruce DePalma, for teaching me how to think about physics - the way things really are. To Trevor Constable, for erasing all doubt in my mind about the reality of the Ether, and for relentlessly pursuing its practical application for the betterment of humanity. To Tom Brown, for introducing me to most of these people, and for broadening my horizons in countless ways.

To Alison Davidson, for permission to use the color image of the etheric discharge from Eric Dollard's magnifying transmitter, taken at the "Integration" in the summer of 1986. To Dorothy O'Connor and Jacqueline Lindemann, for their assistance in editing this book.

And finally, of course, to Edwin V. Gray, Sr. and Dr. Nikola Tesla who, after all, discovered this astonishing technology.

Peter A. Lindemann, D.Sc.  
December 2000

"When the great truth accidentally revealed and experimentally confirmed is fully recognized that this planet with all its appalling immensity is to electrical currents, virtually no more than a small metal ball, and by this fact many possibilities, each baffling imagination and of incalculable consequence, are rendered absolutely sure of accomplishment; when the first plan is inaugurated and it is shown that a telegraphic message, almost as secret and noninterferrable as a thought, can be transmitted 'to any terrestrial distance, the sound of the human voice, with all of its intonations and inflections, faithfully and instantly reproduced at any other point of the globe, the energy of a waterfall made available for supplying light, heat or motive power, anywhere - on sea or land or high in the air - humanity will be like an ant heap stirred up with a stick: see the excitement coming!"

*...Nikola Tesla, 1904*

# Man Creates Engine That Consumes No Fuel; Invention Could Change History by 1984

By TOM VALENTINE  
Copyright 1973, The National Tattler  
(First of a series)

A CALIFORNIA INVENTOR has found a way to create limitless electric power without using up fuel — potentially the greatest discovery in the history of mankind.

Edwin Gray Sr., 48, has fashioned working devices that could:

- Power every auto, train, truck, boat and plane that moves in this land — perpetually.

- Warm, cool and service every American home — without erecting a single transmission line.

- Feed limitless energy into the nation's mighty industrial system — forever.

- And do it all without creating a single iota of pollution.

Already, the jovial, self-educated Gray is forcing scientists to uproot their most cherished beliefs about the nature of electro-magnetism.

Eventually, his discovery will transform the economic base upon which the society of the entire planet has rested up to this point.

Despite the ever-present danger from the petroleum and other power giants who face business extinction within the decade because of his invention, Gray and his associates in EvGray Enterprises have demonstrated its worth publicly — an act requiring great courage.

And TATTLEER is proud to report for the first time in America the complete nature of Gray's astounding system.

Displaying the kind of open honesty that made America great, Gray and his partners stress the fact that they want the whole world to benefit from their new technology.

"I WON'T ALLOW it to be bought up and buried by big money interests," Gray told TATTLEER during the exclusive demonstration.

"I tried for 10 years to get American interests to pay some attention, but I've been tossed out of more places that most people ever think of going into."

Neither government agencies nor private enterprise would listen to Gray, so he turned in frustration to foreign interests. The innovative Japanese were eager to listen.

"AS SOON AS word got out that the Japanese were interested in what we're doing, the Americans started flocking around."

Today, the small shop facility in Van Nuys is crawling with visitors from every segment of U.S. industry and finance.

"The big money boys from Wall Street started coming around," Gray said, with a touch of defiance in his tone.

"A bunch of them came in and suggested I file bankruptcy and get rid of all my backers and friends. Then they talked about giving me 20 million shares of a new corporation at \$5 a share."

Gray was being offered a deal worth more than \$4 billion — on paper.

"THAT SURE sounded rich, but I know darn well they would have fixed it up to sell that corporation off somewhere for a dollar and leave me holding 20 million shares of nothing."

The key men at EvGray include Richard S. Hackenberger, an



Edwin Gray Sr.

electronics engineer who formerly worked for Sony and Sylvania corporations and the U.S. Navy; and Fritz Lens, a former Volkswagen mechanic who knows nearly as much about the fantastic electrical system as Gray.

All the corporate officers agreed that they are determined to get around the money roadblocks and bestow the discovery upon the world.

TATTLEER was given a thorough demonstration of Gray's "impossible-but-true" methods for using electricity.

THE FIRST demonstration proved that Gray uses a totally different form of electrical current—a powerful, but "cold" form of the energy.

A six-volt car battery rested on a table. Lead wires ran from the battery to a series of capacitors which are the key to Gray's discovery. The complete system was wired to two electro-magnets, each weighing a pound and a quarter.

"Now, if you tried to charge those two magnets with juice from that battery and make them do what I'm going to make them do, you would drain the battery in 30 minutes and the magnets would get extremely hot," Gray explained.

"I want you to watch what happens."

As Lens activated the battery, a voltmeter gradually rose to 3,000 volts. At that point, Gray closed a switch and there was a loud popping sound. The top magnet hurtled into the air with tremendous force and was caught by Hackenberger. A terrific jolt of electricity had propelled the top magnet more than

two feet into the air—but the magnet remained cold.

"The amazing thing," Hackenberger said, "is that only 1 per cent of the energy was used—99 per cent went back into the battery."

GRAY EXPLAINED, "The battery can last for a long time, because most of the energy returns to it. The secret to this is in the capacitors and in being able to split the positive."

When Gray said "split the positive" the faces of two knowledgeable physicists screwed up in bewilderment.

(Normally, electricity consists of positive and negative particles. But Gray's system is capable of using one or the other separately and effectively.)

"He means we have to rewrite the physics textbooks," Hackenberger grinned. It has been the engineer's job in recent months to formulate Gray's system and put it in writing.

"That's not an easy task because this system actually defies everything I've ever learned."

Gray said, "I never had no schooling in electronics or physics, so nobody told me it was impossible."

THE "IMPOSSIBLE" part of the demonstration was the lack of heat generated in the magnet. Heat is one of the biggest problems faced by electrical technology. Also "impossible" is the fact that only the "positive" nature of the energy was used.

"This thing is in its infancy," Gray explained. "When the full potential of American technology starts working with it, the results will astound everyone."

A further proof that he has an unusual source of power with unlimited potential was demonstrated next.

"We've been popping those magnets apart for the past 18 months with that same battery and it's still got a full charge. Now I want you to watch this!"

Gray showed this TATTLEER reporter a small 15-amp motorcycle battery. It was hooked up to a pair of his capacitors which in turn were hooked up to a panel of outlets.

HE FLICKED a switch and the tiny battery sent a charge into the capacitors. He then plugged in six 15-watt electric light bulbs on individual cords—a 110-volt portable television set and two radios. The bulbs burned brightly, the television played and both radios blared—and, yet, the small battery was not discharging.

"You couldn't begin to get all this current out of that battery under ordinary circumstances," Gray said.

"This is the most amazing thing I've ever seen," exclaimed C.V. Wood Jr., president of the McCulloch Oil Corporation, who was also present at the demonstration. He began looking around for hidden outlets from the wall.

"MAY I PROVE it doesn't come from any wall plug?" Gray offered. A 40-watt light bulb screwed into an ordinary extension socket was

THE NATIONAL TATTLEER  
Page 5 July 1, 1973

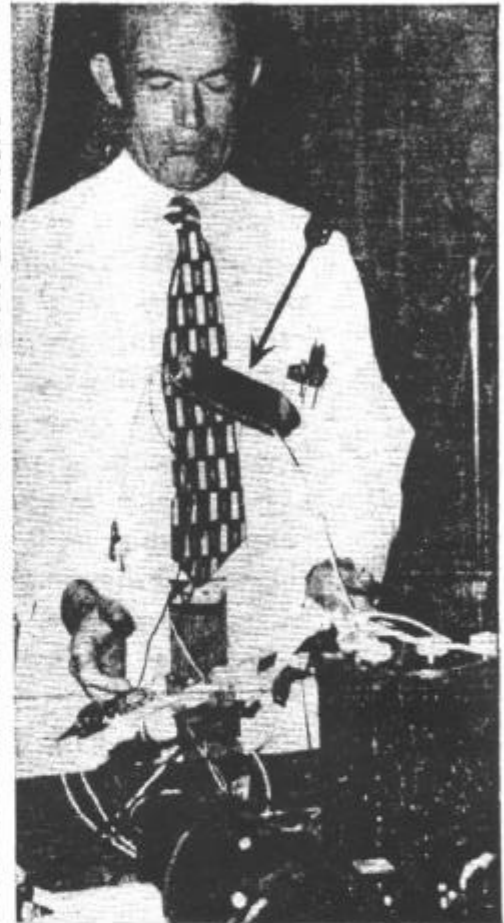

MAGNET JUMPS when jolted with "cool" electricity.

plugged into the panel powered by Gray's system. The bulb lit, then Gray dropped it into a cylinder filled with water.

"What would be happening if this was getting ordinary power right now?" Gray asked, as he stuck his hand in the water with the glowing light bulb.

"You'd be electrocuted and that thing would be popping and sputtering until the fuses blew," Wood replied.

This reporter then put his finger into the water with the light—no shock.

"Gentlemen, this is a new manifestation of electricity," Hackenberger said.

THE ENGINEER told the astounded onlookers that no laws of physics were being violated, but a new application of electricity had been discovered and put to work.

Gray, one of 14 children, comes from Washington, D.C. As a small boy, he was fascinated by electricity, magnets and gadgets in general.

"I really got excited about electricity when they tested the first radar across the Potomac in 1936. I

was 11 years old then and visions of Buck Rogers danced in my head."

He learned about radar during his World War II hitch in the Navy and "I've been messing around with coils and capacitors ever since."

HE LEARNED to "split the positive" in 1958 and spent the next dozen years finding the funds to put his discovery to work.

Any abbreviated explanation of Gray's system is an oversimplification of the technical aspects of this tremendous breakthrough, but some of the best minds in the U.S. are now working with Gray to further improve his discovery.

Gray held the 40-watt bulb up out of the water and said: "You know, to light this bulb takes millions of dollars in power plant facilities, transmission lines and circuitry. With my capacitors, I can provide power to any home for a couple hundred dollars."

The economic impact of that statement is beyond the imagination—not to mention the ecology and anti-pollution benefits.

NEXT WEEK: Electro-magnets automobile engine.

Figure 1  
First Article from *The National Tattler*





## Chapter 1: The Edwin Gray Mystery

My interest in Free Energy began in the summer of 1973 when I first picked up The National Tattler. In an article authored by reporter Tom Valentine, (Figure 1) the headline read: "Man Creates Engine That Consumes No Fuel; Invention Could Change History by 1984." Well, I was young and gullible but I'd sure never seen a newspaper headline like that before. The article went on to say:

**A California inventor has found a way to create limitless electric power without using up fuel, potentially the greatest discovery in the history of mankind. Edwin Gray, Sr., 48, has fashioned working devices that could power every auto, train, truck, boat and plane that moves in this land perpetually; warm, cool, and service every American home without erecting a single transmission line; feed limitless energy into the nation's mighty industrial system forever, and do it all without creating a single iota of pollution.**

After several paragraphs devoted to such subjects as raising capital and bringing a working team together, the article continued to describe two very interesting tests which the writer had personally witnessed at Gray's laboratory in Van Nuys, California in the company of several other scientists:

**The Tattler was given a thorough demonstration of Gray's "impossible but-true" methods for using electricity. The first demonstration proved that Gray uses a totally different form of electrical current - a powerful but "cold" form of the energy. A 6 volt car battery rested on a table. Lead**

**wires ran from the battery to a series of capacitors, which are the key to Gray's discovery. The complete system was wired to two electro-magnets, each weighing a pound and a quarter. "Now if you tried to charge those two magnets with juice from that battery and make them do what I'm going to make them do, you would drain the battery in 30 minutes and the magnets would get extremely hot," Gray explained. "I want you to watch what happens." As Fritz Lens activated the battery, a voltmeter gradually rose to 3,000 volts. At that point, Gray closed a switch and there was a loud popping sound. The top magnet hurled into the air with tremendous force and was caught by Richard Hackenberger. A terrific jolt of electricity had propelled the top magnet more than two feet into the air -but the magnet remained cold. 'The amazing thing,' Hackenberger said "is that only 1% of the energy was used - 99% went back into the battery." Gray explained, "The battery can last for a long time because most of the energy returns to it. The secret to this is in the capacitors and in being able to split the positive." When Gray said "split the positive" the faces of two knowledgeable physicists skewed up in bewilderment. (Normally, electricity consists of positive and negative particles, but Gray's system is capable of using one or the other separately and effectively.)**

Tom Valentine then described the second demonstration as shown in the photograph in Figure 2.

Gray showed this Tattler reporter a small 15-amp motorcycle battery. It was hooked to a pair of his capacitors, which in turn were hooked up to a panel of outlets.

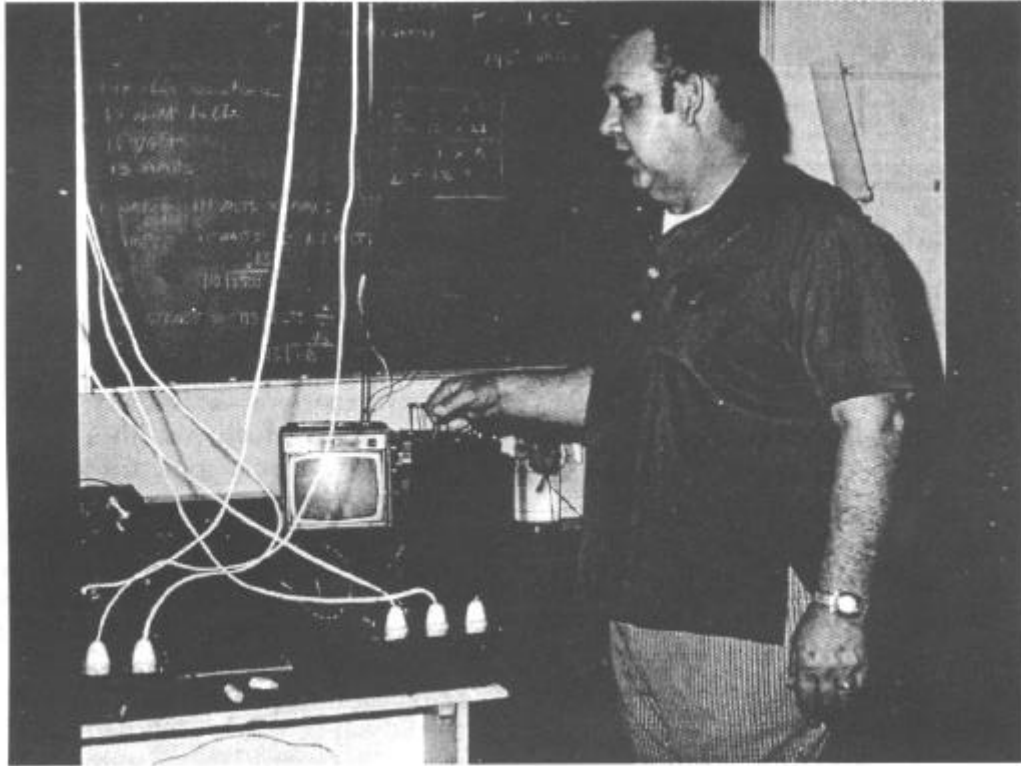

**Figure 2**  
Edwin Gray Demonstrating His Circuit



**Figure 3**  
Tom Valentine With "Cold" Light Bulb in Water

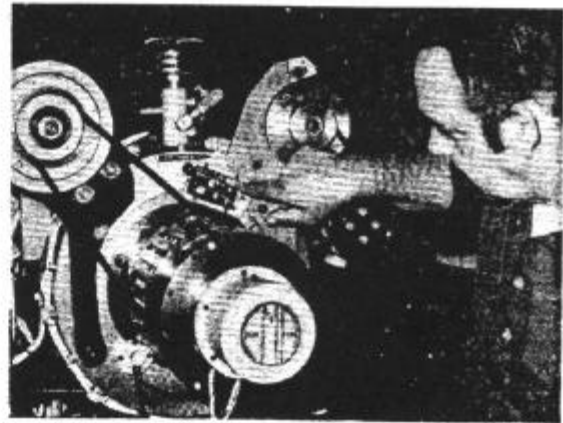
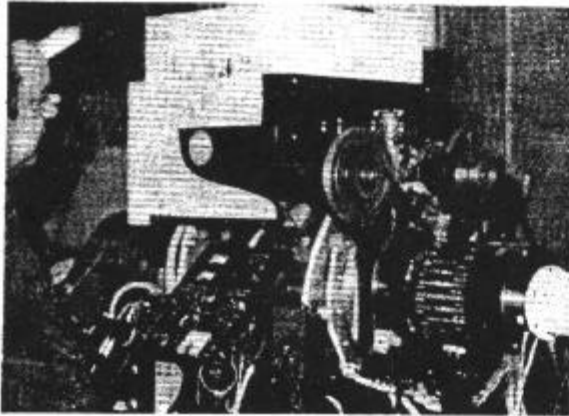

THIS IS THE 'EMA,' which can run perpetually on batteries that recharge themselves, develop 1,000 horsepower per unit.

## Miracle No-Fuel Electric Engine Can Save U.S. Public \$35 Billion a Year in Gasoline Bills

BY TOM VALENTINE

Copyright 1972, The National Tattler

(Second of Two Articles)

An inventor and his small but stubborn team of engineers has devised the most revolutionary technological advance in the history of mankind: A power source that uses no fuel.

As reported exclusively last week in TATTLER, the astonishing new system creates electricity without consuming the world's dwindling supply of fossil fuel, without creating pollution, and without using costly and unsightly transmission lines.

The first and most vital outcome of the theory that is forcing the science of physics to revise its fundamental assumptions is the "EMA" electric engine—a power plant that dooms noisy, dirty gasoline motors.

That means that the nation would no longer have to consume expensive and belching gasoline. According to figures from the American Petroleum Institute, the anticipated consumption this year is 100 billion gallons at least \$35 billion worth at the pump.

Invented by Edwin Gray Sr., 48, of Van Nuys, Calif., the engine has been tested and is being perfected by him and his associates in EvGray Enterprises.

The silent, pollution-free EMA recycles its own energy and can run indefinitely.

Gray's prototype is powered by four six-volt batteries which "will wear out before they'll run down," as the inventor puts it.

"WE CAN GO up to 1,000 horsepower with a single unit, or down to a miniature toy size."

The latter suits, in fact, will be among the first products EvGray manufactures. They'll run off a tiny battery unit.

**How?**  
Gray and his engineers, Richard Hackenberger and Fritz Lens, explained to TATTLER that they have found a way to use both the positive and negative particles of electricity separately.



Edwin Gray Sr.

The technicians demonstrated for this reporter the phenomenon of electromagnetic repulsion—the power source for the EMA.

**TWO MAGNETS**, each weighing 1 3/4 pounds were repelled apart with an explosive force, but the magnets did not heat up and 96 per cent of the energy recycled to the battery.

The same "cold" energy repelling magnets, arranged on a flywheel,

run the motor.

Hackenberger, an electronics specialist, explained: "A series of high-voltage energy 'spikes' are developed by our circuitry. These energy units are transferred to a control unit, which acts much like a distributor in an internal combustion engine."

The control unit is the key to the motor's efficiency. It regulates the energy spikes to determine the polarity (north or south) and directs the voltage into selected electromagnets in the main unit.

"Every time a magnet is charged, most of the energy is recycled back into the batteries without losing power," Hackenberger said.

THE EMA has been tested thoroughly. Its efficiency is undisputed.

"Engineers and physicists who see it operate have a hard time believing their eyes," Gray said. "One professor from UCLA insisted we had some sort of laser beam running it, and even though we moved it from room to room, he wouldn't believe it."

While the motor was running, Gray spun it around in a complete circle to demonstrate that it operated at any position.

The experimental model engine is 42 inches long, 18 inches wide and 22 inches high about the size of a standard six-cylinder motor.

IT TURNED better than 2,500 revolutions per minute for more than 20 minutes. The power input came from the four six-volt batteries. At the end of the trial they were tested and found to be as fully charged as they were at the beginning.

It generated 100 horsepower and 66 pounds of constant torque. The brake horsepower tests out at 32.05.

The motor has only two bearings which require lubrication, so maintenance costs will be minimal; it operates at a maximum temperature of about 175 degrees and is cooled by compressed air.

There was no vibration and the



### Unique All-Girl Diving Co.

Christine Bouse, the girl at the left, may be the only teenage girl in the world to run her own underwater salvage company. While other girls her age are busy with boys, clothes and record albums, 16-year-old Chris spends most of her time in scuba diving gear at the bottom of some Florida river or lagoon. Chris, together with her partner, 18-year-old Linda Marquis, and five other 18-year-old girls, operates Sea Queen Salvage—probably the only licensed commercial diving company anywhere staffed entirely by attractive young women. Chris, pictured here with her sister, Carol Beth, works, however. She inherited her skill in the diving business from her father, Clyde (Buddy) Bouse, (at right) a 22-year veteran of underwater salvage work. "Chris is as good as diver as I'll ever be," said her father.

noise level was about the same as any kitchen appliance, this reporter observed.

It started with the flick of a switch. It can be accelerated or slowed by any mechanical device which programs the control unit. This means the customary foot pedal could be used for driving purposes.

GRAY DISCOVERED how to make this remarkable engine back in 1968. He fought frustration and

scepticism for 10 years before finally getting about \$1.1 million to help build and prove the prototype.

The search for an efficient, clean engine has cost taxpayers nearly a billion dollars in government research grants over the years.

Ed Gray did it on a fraction of that and a new direction for mankind has been uncovered.

THE NATIONAL TATTLER  
July 8, 1972

Page 5

Figure 4

Second Article from *The National Tattler*

He flicked a switch and the tiny battery sent a charge into the capacitors. He then plugged in six 15-watt electric light bulbs on individual cords, a 110-volt portable television set and two radios. The bulbs burned brightly, the television played and both radios blared and yet the small battery was not discharging. 'You couldn't begin to get all this current out of that battery under ordinary circumstances,' Gray said.

'This is the most amazing thing I've ever seen,' exclaimed C.V. Wood, Jr., president of the McCulloch Oil Corporation, who was also present at the demonstration. He began looking around for hidden outlets from the wall. 'May I prove it doesn't come from any wall plug?' Gray offered. A 40-watt light bulb screwed into an ordinary extension socket was plugged into the panel powered by Gray's system.

The following portion of the demonstration is shown in the photograph in Figure 3:

The bulb lit, then Gray dropped it into a cylinder filled with water. 'What would be happening if this was getting ordinary power right now?' Gray asked, as he stuck his hand in the water with the glowing light bulb. 'You'd be electrocuted and that thing would be popping and sputtering until the then put his finger into the water with the light. No shock. 'Gentlemen, this is a new manifestation of electricity,' Hackenberger said.

Well, this was quite literally the most amazing thing I had ever read in a newspaper. I was completely hooked. The next week I picked up the second article in the series, titled "Miracle No Fuel Electric Engine Can Save Public \$35 Billion A Year In Gasoline Bills" (Figure 4). It centered on an amazing new type of electric motor that ran on Gray's system:

The silent pollution-free EMA motor recycles its own energy and can run indefinitely. Gray's prototype is powered by four 6-volt batteries which 'will wear out before they'll run down.' The same 'cold' energy repelling magnets, arranged on a

flywheel, run the motor. Hackenberger, an electronics specialist explained, 'A series of high-voltage energy spikes are developed in our circuitry. These energy units are transferred to a control unit which acts much like a distributor in an internal combustion engine. Every time a magnet is charged, most of the energy is recycled back into the batteries without losing power.'

## THE ENGINE THAT RUNS ITSELF

An unconventional approach to harnessing energy has created a motor that requires no fuel and produces no waste. Its inventor says it is the answer to many transportation and power problems.

BY JACK SCAGNETTI

Science's Effect on Water is Not the Only One

For the first time, a motor has been developed that requires no fuel and produces no waste. Its inventor says it is the answer to many transportation and power problems.

The inventor of the motor, C.V. Wood, Jr., president of the McCulloch Oil Corporation, says the motor is the answer to many transportation and power problems.

The motor is the answer to many transportation and power problems. It is the answer to many transportation and power problems.

The motor is the answer to many transportation and power problems. It is the answer to many transportation and power problems.

The motor is the answer to many transportation and power problems. It is the answer to many transportation and power problems.

The motor is the answer to many transportation and power problems. It is the answer to many transportation and power problems.

The motor is the answer to many transportation and power problems. It is the answer to many transportation and power problems.

The motor is the answer to many transportation and power problems. It is the answer to many transportation and power problems.

The motor is the answer to many transportation and power problems. It is the answer to many transportation and power problems.

The motor is the answer to many transportation and power problems. It is the answer to many transportation and power problems.

The motor is the answer to many transportation and power problems. It is the answer to many transportation and power problems.

The motor is the answer to many transportation and power problems. It is the answer to many transportation and power problems.

The motor is the answer to many transportation and power problems. It is the answer to many transportation and power problems.

The motor is the answer to many transportation and power problems. It is the answer to many transportation and power problems.

The motor is the answer to many transportation and power problems. It is the answer to many transportation and power problems.

The motor is the answer to many transportation and power problems. It is the answer to many transportation and power problems.

The motor is the answer to many transportation and power problems. It is the answer to many transportation and power problems.

The motor is the answer to many transportation and power problems. It is the answer to many transportation and power problems.

The motor is the answer to many transportation and power problems. It is the answer to many transportation and power problems.

The motor is the answer to many transportation and power problems. It is the answer to many transportation and power problems.

The motor is the answer to many transportation and power problems. It is the answer to many transportation and power problems.

Figure 5

Article from *Probe The Unknown*

Around that same time, there appeared another article in a magazine called *Probe The Unknown* authored by Jack Scagnetti called "The Engine That Runs Itself." (Figure 5) He presented very similar information as that contained in the articles by Tom Valentine. Gray describes the operation of his EMA motor as similar to recreating lightning:

Richard Hackenberger, Vice President in Engineering for EVGray, explains how the EMA motor system operates. 'Power from the high voltage section is put through a system of electrical circuitry to produce a

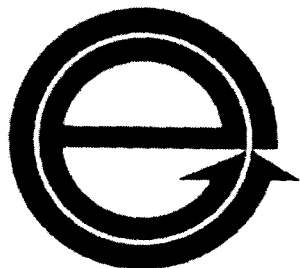

**EVGRAYENTERPRISES, INC.**

14737 CALVERT STREET VAN NUYS, CALIFORNIA 91401

Telephone 213 989 4210

October 11, 1973

Peter A. Lindemann  
P.O. Box 354  
Mountainview Ha. 96771

Dear Mr. Peter A. Lindemann,

I would like to thank you for showing such interest in EvGray Ent. Inc. and for taking the time to write to us, I have also sent your brother a letter.

But due to our security we are unable to give out any information about the motor or the company.

Thank you,

A handwritten signature in cursive script that reads "Renate Gray".

Renate Gray

**Figure 6**  
Letter from EVGray Enterprises

series of high voltage energy spikes. The spikes are transferred to a control unit, which in turn operates the major motor unit'. 'While this occurs, the recycle/ regeneration system is recharging the battery with 60 to 120 amp pulses.'

These several newspaper articles totally captivated my imagination. Shortly afterwards, my brother and I wrote to EVGray Enterprises in Van Nuys, California expressing our interest and desire to have more information. I received the following letter from them in October, 1973: "**Dear Mr. Lindemann: I would like to thank you for showing such interest in EVGray Enterprises, Inc. and for taking the time to write us. I have also sent your brother a letter. But due to our security, we are unable to give out any information about the motor or the Company.**" (Figure 6) Needless to say, this was extremely disappointing. So, reluctantly, I put the Valentine and Scagnetti articles and the

letter from EVGray away in a file, which eventually grew into my very extensive research on the subject of "Free Energy."

Unfortunately, I didn't read any more about Ed Gray for the next couple of years. In 1977, however, I came across another article by Tom Valentine in an issue of a magazine called NewsReal (Figure 7) devoted to suppressed inventions. Valentine wrote about a wide variety of subjects ranging from making oil from coal, to making gasoline from water, to airplanes that won't stall, and other amazing inventions. Included was an update on Edwin Gray entitled, "EMS - Electronic Power That Could Change The World's Economic Power Picture." (Figure 8)

In this article, Ed Gray says:

**'I remember getting a shock when I grabbed a charged capacitor off a workbench. That simple fact never left my mind. Then I watched when the government people were testing the first radar across the Potomac River. It stuck in my mind when one of the men explained it as 'pulse out, pulse back'. And I've always been a nut about thunderstorms. I watched lightning by the hours. I noticed how much stronger it appeared to be when closer to the earth, and just naturally concluded that the more air had something to do with it. These three principles, plus a super secret means of generating and mixing static electricity, make up Gray's EMS motor.'**

Later in the article:

**'There is no motor like this in the world' Dr. Chalfin told the group. 'Ordinary electric motors use continuous current and constantly drain power. In this system, energy is used only during a small fraction of a millisecond. Energy not used is returned to an accessory battery for reuse.' 'It is cool running,' Dr. Chalfin added, putting his hand on the motor. 'There is no loss of energy in the system.'**

Gray's first patent, issued in June of 1975, was titled "Pulsed Capacitor Discharge Electric Engine." (Figure 9) I



**Figure 7**  
Cover of *NewsReal* Magazine

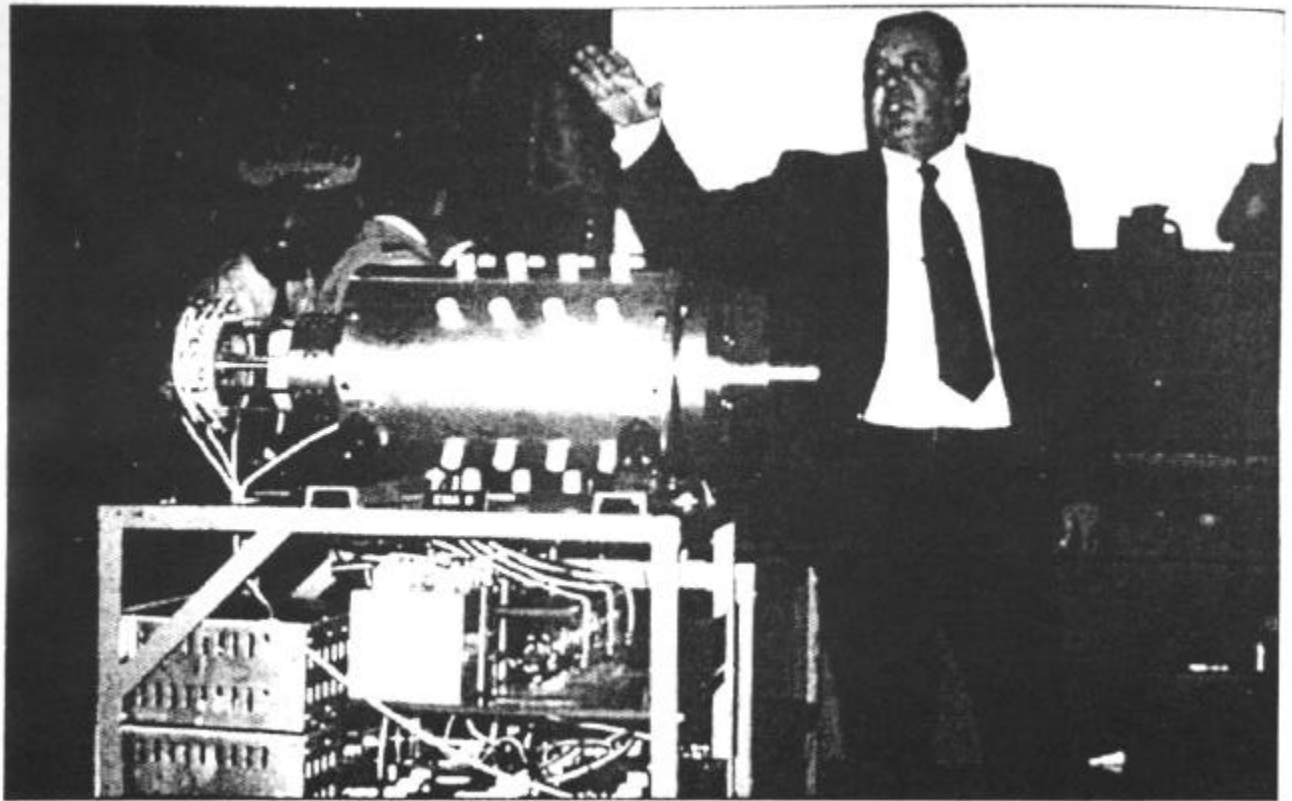

Ed Gray hailed his invention before stockholders, 1976.

## EMS --Electronic Power That Could Change The World's Economic Power Picture

**T**hough harrassed by the authorities, under-financed and ignored by science, business and industry, Edwin V. Gray, a self educated Los Angeles inventor has developed a revolutionary electromagnetic motor that promises to greatly improve conditions for the world.

A vast new technology is opening because Gray invented a motor that delivers super-efficient horsepower at lower cost with less wear and tear than any other device known. His EMS motor takes us a giant step closer to the magnificent, whirring power plants visualized by science fiction writers.

Implications for the auto industry alone are staggering: Gray appears to have the answer to Detroit's dilemma involving practical electric vehicles.

Ed Gray's name may well go down in history alongside the likes of Edison, Marconi, Goddard and Bell -

that is, if the establishment will get off his back.

A social quality known as "resistance to change" and another called the "economic status quo" have made Gray's struggle to develop and market his motor a tale of bitter frustration. Most people would have quit in despair long ago.

However, tireless experimentation and remarkable determination have paid off in a technological triumph that brings the heretofore untapped source of static electricity into the workhouse of man. Any expert can tell you "static electricity will not do work." Gray is slowly and doggedly proving the experts are wrong.

His battle is not over, but perhaps the tide is finally turning in his favor. His corporation, EsGray Enterprises, is seeking the necessary financing to further develop the motor. His efforts

were thwarted by serious legal problems which recently were resolved when he agreed to enter a guilty plea to a minor Securities and Exchange violation.

Thus nearly two years of legal entanglements came to a close. The legal costs alone have been near ruinous.

He's won some important battles, but he could yet lose the war.

Gray's start in life wasn't promising. He was one of six children of a poor Washington, D.C. family and grew up in the streets.

Few suspected he had the stuff of a genius. Like many kids, he was fascinated by engines and motors, but his thinking about them went far beyond normal curiosity. He wanted to know more than just what made them run.

Gray dropped out of school at 14 and began tinkering with ideas. He was so lacking in formal education that he





Figure 9  
Gray's Motor Patent Cover Sheet

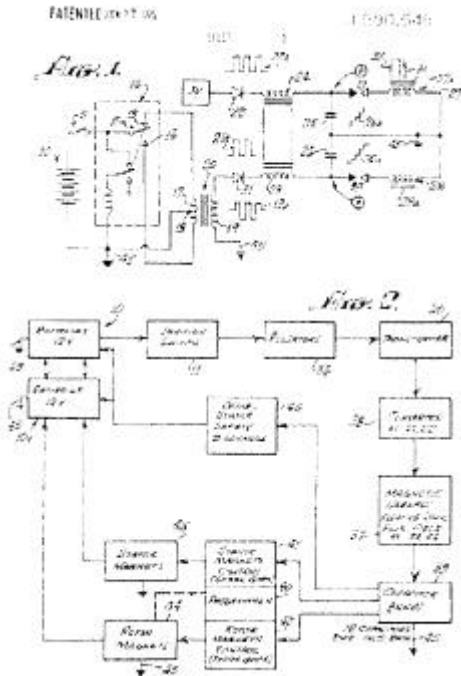

Figure 10  
Gray's Motor Patent Schematic

received a copy of it in 1978. It is a rather extensive patent with 18 pages, 19 illustrations, and 18 claims. It describes an engine that is run by discharging capacitors through electromagnets that oppose each other. (Figure 10)

But I discovered soon enough that if you try to build this motor according to the principles outlined in this patent, it doesn't perform anything like what was described in the Valentine articles. In fact, it doesn't produce a cold form of electricity at all. If you happened to get into the discharge path of those capacitors, you'd be thrown clear across the room. What's more, the amount of energy that could be recycled from this arrangement is negligible compared to what Gray is talking about in those articles. It became quite obvious to me, that in spite of the fact that this patent protected the specific design of the motor, it did not reveal the *technique* of its operation.

From the beginning, I was always more interested in the solid-state circuit. I realized that the production of cold electricity really had nothing to do with the motor and that the motor was a secondary event. After all, when Gray was popping the magnets with cold electricity and running the TV and the light bulbs on cold electricity, he didn't need the motor. Intuitively, I knew from the outset that the key to unraveling the secret of Gray's discovery lay in an attempt to completely understand his solid-state circuit. However, the resources I had gathered thus far were inadequate at best, and by the late 70's, I had pretty much exhausted all the information that was available on this subject.

During the late 1980's, I only heard rumors that Gray was continuing his work, but all I could really determine was that no more news articles, or anything else for that matter, ever appeared about him.



In the mid-1990's, however, a research associate of mine told me that he had heard that Gray had been issued other patents and this completely intrigued me. Would these new patents contain the answers I was looking for? I didn't know for sure, but I knew I needed to get hold of these documents. Unfortunately, my associate didn't have them, and he didn't know what the patent numbers were. So once again, my search for Ed Gray's "cold electricity" came to a dead end, at least for a few more years.

In June of 1999, while visiting the IBM Intellectual Property Network on the internet (now the Delphion Intellectual Property Network), I noticed that the search engines within the patent database had been recently updated so it was now possible to restrict a search just to the Inventor Line. "Gray" into a search and looked at every word in every patent from 1971 forward, you got so many hits you couldn't possibly go through them all. Now, however, I was able to plug "Gray; Edwin" into the Inventor Line of this newly updated search engine. Lo and behold, on my screen 30 seconds later, the numbers of two other patents that had been issued to Edwin Gray came up. I was ecstatic!

Figure 11 shows the first of these patents entitled "Efficient Power Supply Suitable for Inductive Loads" issued in June 1986. Understanding this patent will be the primary focus of this book.

The other patent entitled "Efficient Electrical Conversion Switching Tube Suitable for Inductive Loads" (Figure 12) was issued approximately ten months later, in April 1987.

These two patents are very closely linked and are almost identical. One of them describes the circuit that drives this switching tube and the other one describes the switching tube itself. About 80% of

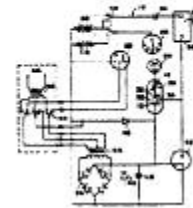

Figure 11  
Gray's Circuit Patent Cover Sheet

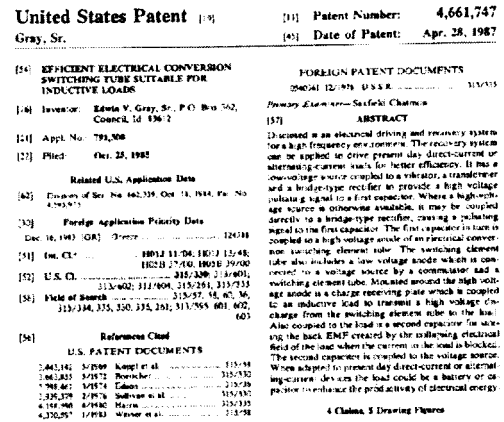

Figure 12  
Gray's Conversion Tube Patent Cover Sheet

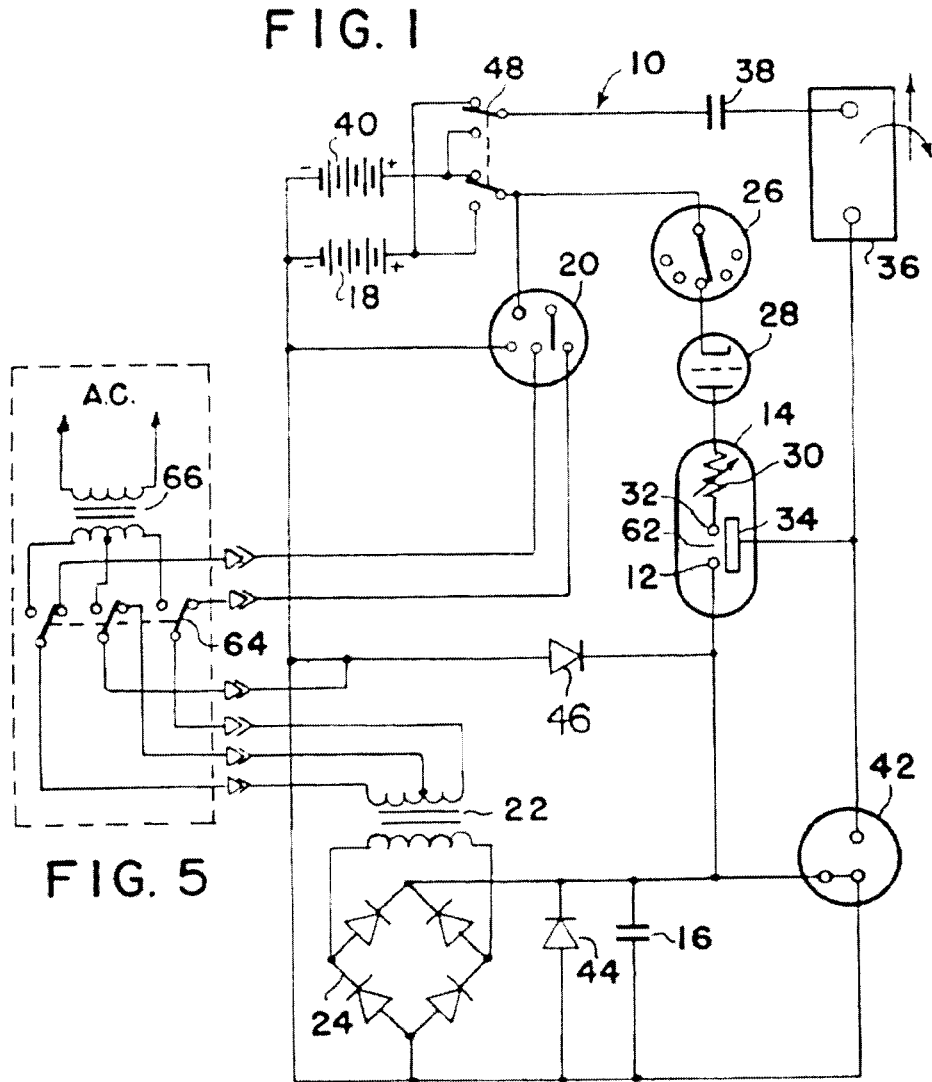

Figure 13  
Gray's Circuit "Schematic"

the wording in both of these patents is identical.

Figure 13 shows the circuit diagram for the first one. I had searched 26 years for this diagram, and finally I had a chance to understand what Gray was doing. I felt sure that I was looking at the basis of his "cold" electricity circuits, but Gray was still holding his cards quite close to his chest. Reading the diagram, it was not clear how these components behaved, or what they did, or why. The more I studied the text, which is relatively short compared to the motor patent, the more I realized I was looking at something that was really quite foreign to me. Intuitively, I felt I had all the pieces, but I still didn't know how the pieces fit together, and I didn't know what the true picture looked like. Why was this circuit able to create free energy? Once again, there were still far too many unknowns.

I was heartened, though, by several interesting references stated in the patent. For instance, in one small section, Gray states:

**There is disclosed herein an electrical driving system which, on theory, will convert low-voltage electrical energy from a source, such as an electric storage battery, to a high-potential, high-current energy pulse that is capable of developing a work force at the inductive output of the device that is more efficient than that which is capable of being developed directly from the energy source.**

That statement may sound a bit obscure, but actually as far as I was concerned, it was a pretty sneaky way of saying "free energy." Further on it says:

**This system accomplishes the results stated above by harnessing the 'electro-static' or 'impulse' energy created by a high intensity spark generated within a specially constructed electrical conversion switching element tube. This element utilizes a low voltage anode, a high voltage anode, and one or more electro-static or charge receiving grids. These grids are of a**

**physical size, and appropriately positioned, as to be compatible with the size of the tube, and therefore, directly related to the amount of energy to be anticipated when the device is operating**

As I continued to read this patent, I was most intrigued by components # 42, # 44, and # 46. The patent states:

**A spark-gap protection device, 42, is included in the circuit to protect the inductive load and the rectifier elements from unduly large discharge currents. Should the potentials within the circuit exceed predetermined values, fixed by the mechanical size and spacing of the elements within the protected device, the excess energy is dissipated (bypassed) by the protective device to the circuit common (electrical ground)... diodes 44 and 46 bypass the excess overshoot generated when the energy conversion switching element tube is triggered.**

So here we have three elements, # 42, # 44 and # 46 in this circuit, which are specifically designed to dump excess energy when this tube fires! What this suggests is that there is the possibility of producing so much energy here that it can damage the rest of the circuit. Certainly this was quite promising, but I still didn't really understand what phenomenon would create those conditions -- or why. It was definitely apparent to me, however, that Gray expected something extremely "large" to happen when this conversion switching tube fired.

I was convinced I had discovered the secret of the device, but I still didn't really understand what I was looking at. I needed a "Rosetta Stone" -- something that would translate all of these unknowns into an understandable context.

Luckily, I found it. That Rosetta Stone was a book called *Secrets of Cold War Technology: Project HAARP and Beyond*, written by Gerry Vassilatos in 1996 and currently available through Adventures Unlimited Press (Figure 14). In Chapter 1,

titled "Nikola Tesla and Radiant Energy," Vassilatos recounts those heady days back around 1890, when Nikola Tesla is developing the experiments which led to the invention of his magnifying transmitter. It is an astonishing work, and I highly recommend that you acquire and read the entire publication. However, for the purposes of this book, the following excerpted sections from Chapter I will reveal not only a fascinating story of discovery, but, more importantly, will provide the foundation for full comprehension of Tesla's amazing magnifying transmitter and, subsequently, its connection to Edwin Gray's "cold electricity" circuit.



**Figure 14**  
*Secrets of Cold War Technology:  
Project HAARP and Beyond*

# Edwin Vincent Gray

(1925 - 1989)

Edwin Gray was born in Washington, DC in 1925. He was one of 14 children. At age eleven, he became interested in the emerging field of electronics when he watched some of the first demonstrations of primitive radar being tested across the Potomac River. He left home at 15 and joined the Army, attending their advanced engineering school for one year before he was discovered and honorably discharged for being under age. After the attack on Pearl Harbor, he re-enlisted in the Navy and served three years of combat duty in the Pacific.

After the War, he worked as a mechanic and continued his studies in electro-magnetics. After experimenting for years, he learned how to "split the positive" in 1958 and had his first Electric Magnetic Association (EMA) motor model running in 1961. His third EMA prototype was successfully tested for 32 days straight before it was torn down for analysis. With this report in hand, Gray started looking for serious funding. After being turned down by every major corporation and venture capital group he approached, he formed his own limited partnership in 1971. By early 1973, EVGray Enterprises, Inc. had an office in Van Nuys, California, hundreds of private investors and a new (# 4) EMA motor prototype. Ed Gray had also received a "Certificate of Merit" from Ronald Reagan, then Governor of California.

By the summer of 1973, Gray was doing demonstrations of his technology and receiving some very positive press. By later that year, Gray had teamed up with automobile designer, Paul M. Lewis, to build the first fuelless, electric car in America. But trouble was brewing.

On July 22, 1974 an unprovoked Los Angeles District Attorney's Office raided the office and shop of EVGray Enterprises, and confiscated all of their business records and working prototypes. For 8 months, the DA tried to get Gray's stockholders to file charges against him, but none would. Gray was eventually charged with "grand theft," but even this bogus charge couldn't stick and was finally dropped. By March 1976, Gray pleaded guilty to two minor SEC violations, was fined, and released. The DA's office never returned his prototypes.

In spite of these troubles a number of good things were happening. His first US. Patent, on the motor design, issued in June of 1975, and by February 1976, Gray was nominated for "Inventor of the Year" for "discovering and proving a new form of electric power" by the Los Angeles Patent Attorney's Association. Despite this support, Gray kept a much lower profile after this time. In the late 1970's, Zetech, Inc. acquired Gray's technology and EVGray Enterprises ceased to exist. In the early 1980's, Gray offered the US. Government his technology to augment Reagan's SDI program. He actually wrote letters to every member of Congress, both Senators and Representatives, as well as the President, Vice President, and every member of the Cabinet. Remarkably, in response to this letter writing campaign, Gray did not receive a single reply or even an acknowledgment! During the early 1980's, Gray lived in Council, Idaho, where he wrote and was granted his other two US Patents. By 1986, he had a facility in Grande Prairie, Texas, where a number of new prototype EMA motors were built. By 1989, he was working on propulsion applications of the technology, and maintaining his residence in Council, Idaho, as well as shop facilities in Council, Grande Prairie, and Sparks, Nevada.

Edwin V. Gray died at his shop in Sparks, Nevada, in April 1989, under mysterious circumstances. He was 64 and in good health.



The following chapter is excerpted from Chapter 1 of *Secrets of Cold War Technology: Project HAARP and Beyond*, by Gerry Vassilatos and is reprinted here by permission of the publisher, Adventures Unlimited Press.

## Chapter 2: The Rosetta Stone

James Clerk-Maxwell predicted the possibility that electromagnetic waves might exist. In theoretical discussions designed to more thoroughly explain his mathematical descriptions, Maxwell asked his readers to consider two different kinds of electrical disturbances possibly existing in nature. The first consideration dealt with longitudinal electric waves, a phenomenon, which required alternating concentrations of electrostatic field lines. This densified and rarefied pulsation of electrostatic fields necessarily demanded a unidirectional field, one whose vector was fixed in a singular direction. The only variable permitted in generating longitudinal waves was the concentration of the field. Subsequent propagation along the electrostatic field lines would produce pulsating thrusts of charges, pulsation moving in a single direction. These “electrical soundwaves” were rejected by Maxwell, who concluded that such a condition was impossible to achieve.

His second consideration dealt with the existence of transverse electromagnetic waves. These required the rapid alternation of electrical fields along a fixed axis. Space spreading electrical lines would supposedly “bend to and fro” under their own momentum, while radiating away at the speed of light from the alternating source. Corresponding forces, exact duplicates of the alterations produced at the source, would be detected at great distances. He encouraged that experimenters seek this

waveform, suggesting possible means for achieving the objective. And so the quest to find electromagnetic waves began.

In 1887, Heinrich Hertz announced that he had discovered electromagnetic waves, an achievement at that time of no small import. In 1889, Nikola Tesla attempted the reproduction of these Hertzian experiments. Conducted with absolute exactness in his elegant South Fifth Avenue Laboratory, Tesla found himself incapable of producing the reported effects. No means however applied would produce the effects which Hertz claimed. Tesla began experimenting with abrupt and powerful electric discharges, using capacitors charged to very high potentials. He found it possible to explode thin wires with these abrupt discharges. Dimly perceiving something of importance in this experimental series, Tesla abandoned these experiments, all the while pondering the mystery and suspecting that Hertz had somehow mistakenly associated electrostatic inductions or electrified shockwaves in air for true electromagnetic waves. In fact, Tesla visited Hertz and personally proved these refined observations to Hertz who, being convinced that Tesla was correct, was about to withdraw his thesis. Hertz was truly disappointed, and Tesla greatly regretted having to go to such lengths with an esteemed academician in order to prove a point.

But while endeavoring toward his own

means for identifying electrical waves, Tesla was blessed with an accidental observation, which forever changed the course of his experimental investigations. In his own attempts to achieve where he felt Hertz had failed, Tesla developed a powerful method by which he hoped to generate and detect real electromagnetic waves. Part of this apparatus required the implementation of a very powerful capacitor bank. This capacitor "battery" was charged to very high voltages, and subsequently discharged through short copper bus bars. The explosive bursts thus obtained produced several phenomena, which deeply impressed Tesla, far exceeding the power of any electrical display he had ever seen. These proved to hold an essential secret, which he was determined to uncover.

The abrupt sparks, which he termed "disruptive discharges", were found capable of exploding wires into vapor. They propelled very sharp shockwaves, which struck him with great force across the whole front of his body. Of this surprising physical effect, Tesla was exceedingly intrigued. Rather, more like gunshots of extraordinary power than electrical sparks, Tesla was completely absorbed in this new study. These electrical impulses produced effects commonly associated only with lightning. The explosive effects reminded him of similar occurrences observed with high voltage DC generators. A familiar experience among workers and engineers, the simple closing of a switch on a high voltage dynamo often brought a stinging shock, the assumed result of residual static charging.

This hazardous condition only occurred with the sudden application of high voltage DC. This crown of deadly static charge stood straight out of highly electrified conductors, often seeking ground paths which included workmen and switchboard operators. In long cables, this instantaneous charge effect produced a hedge of bluish

needles, pointing straight away from the line into the surrounding space. The hazardous condition appeared briefly at the very instant of switch closure. The bluish sparking crown vanished a few milliseconds later, along with the life of any unfortunate who happened to have been so "struck". After the brief effect passed, systems behaved as designed. Such phenomena vanished as charges slowly saturated the lines and systems. After this brief surge, currents flowed smoothly and evenly as designed.

The effect was a nuisance in small systems. But in large regional power systems where voltages were excessive, it proved deadly. Men were killed by the effect, which spread its deadly electrostatic crown of sparks throughout component systems. Though generators were rated at a few thousand volts, such mysterious surges represented hundreds of thousands, even millions of volts. The problem was eliminated through the use of highly insulated, heavily grounded relay switches. Former engineering studies considered only those features of power systems that accommodated the steady state supply and consumption of power. It seemed as though large systems required both surge and normal operative design considerations. Accommodating the dangerous initial "supercharge" was a new feature. This engineering study became the prime focus of power companies for years afterward, safety devices and surge protectors being the subject of a great many patents and texts.

Tesla knew that the strange supercharging effect was only observed at the very instant in which dynamos were applied to wire lines, just as in his explosive capacitor discharges. Though the two instances were completely different, they both produced the very same effects. The instantaneous surge supplied by dynamos briefly appeared super-concentrated in long



Lines. Tesla calculated that this electrostatic concentration was several orders in magnitude greater than any voltage that the dynamo could supply. The actual supply was somehow being amplified or transformed. But how?

The general consensus among engineers was that this was an electrostatic “choking” effect. Many concluded it to be a “bunching” action, where powerfully applied force was unable to move charge quickly through a system. Mysterious, the combined resistance of such systems seemed to influence the charge carriers before they were able to move away from the dynamo terminals! Like slapping water with a rapid hand, the surface seemed solid. So also it was with the electrical force, charges meeting up against a seemingly solid wall. But the effect lasted only as long as the impact. Until current carriers had actually “caught up” with the applied electrical field, the charges sprang from the line in all directions. A brief supercharging effect could be expected until the charges were distributed, smoothly flowing through the whole line and system. The dynamo itself thus became the brief scene of a minor shockwave. He began wondering why it was possible for electrostatic fields to move more quickly than the actual charges themselves, a perplexing mystery. Was the field itself an entity that simply drive the more massive charges along? If this was true, then of what was the electrostatic field itself “composed”? Was it a field of smaller particles? The questions were wonderfully endless.

Despite the wonderful ideas, which this study stimulated, Tesla saw a practical application that had never occurred to him. Consideration of the dynamo supercharging effect suggested a new experimental apparatus. It was one that could greatly outperform his capacitor battery in the search to find electrical waves. A simple high voltage DC generator provided his

electric field source. Tesla understood that the resistance of lines or components, viewed from the dynamo end, seemed to be an impossible “barrier” for charge carriers to penetrate. This barrier caused the “bunching” effect. Electrostatic charges were literally stopped and held for an instant by line resistance, a barrier which only existed during the brief millisecond interval in which the power switch was closed. The sudden force application against this virtual barrier squeezed charge into a density impossible to obtain with ordinary capacitors. It was the brief application of power, the impact of the charge against the resistance barrier, which brought this abnormal electro-densified condition. This is why the conductive wires in his present experiment often exploded.

The analogy to steam power and steam engines was unmistakable: Large steam engines had to be valved very carefully. This required the expertise of old and well-experienced operators who knew how to “open up” an engine without rupturing the vessels and causing a deadly explosion. Too suddenly valved, even a large steam engine of very high capacity could explode. Steam had to be admitted into a system gently, until it began smoothly and gradually flowing into every orifice, conduit, and component. Here too was the mysterious “choking” effect, where a large capacity system seemed to behave like an uncommonly high resistance to any sudden and sustained application of force.

The academic world of experimenters was yet fixated on his former discovery of high frequency alternating currents. It seemed that Tesla alone now exclusively studied these impulse discharges. He was producing explosive impulses, which had not been observed in laboratories. Every component was carefully insulated, himself implementing insulator rods and rubberized regalia to insure complete safety. Tesla had observed electrostatic machines whose

ability to charge insulated metals was potent, but this demonstration exceeded the mere charging of wire by the instantaneous switch closure. This effect produced "springing" charge, phenomena like no other before witnessed by Tesla for its sheer strength. Whatever the conditions observed in previous systems, he had now learned how to maximize the effect. Balancing voltage and resistance against capacity, Tesla learned to routinely produce supercharge states which no existing device could equal

Empirical observation had long taught that ordinary capacitor discharges were oscillating currents, spark currents which literally "bounced" between each capacitor plate until their stored energy was wasted away. The high voltage of the dynamo exerted such an intense unidirectional pressure on the densified charges that alternations were impossible. The only possible backrushes were oscillations. In this case, charges surged and stopped in a long series until the supercharge was wasted away. All parameters which forced such oscillations actually limited the supercharge from manifesting its total energetic supply, a condition Tesla strove to eliminate. Indeed he spent an excessive time developing various means to block every "backrush" and other complex current echo which might force the supercharge to prematurely waste its dense energy. Here was an effect demanding a single unidirectional super pulse. With both the oscillations and alternations eliminated, new and strange effects began making their appearance. These powerful and penetrating phenomena were never observed when working with high frequency alternations.

The sudden quick closure of the switch now brought a penetrating shockwave throughout the laboratory, one that could be felt both as a sharp pressure and a penetrating electrical irritation. A "sting". Face and hands were especially sensitive to the explosive shockwaves, which also

produced a curious "stinging" effect at close range. Tesla believed that material particles approaching the vapor state were literally thrust out of the wires in all directions. In order to better study these effects, he poised himself behind a glass shield and resumed the study. Despite the shield, both shockwaves and stinging effects were felt by the now mystified Tesla. This anomaly provoked a curiosity of the very deepest kind, for such a thing was never before observed. More powerful and penetrating than the mere electrostatic charging of metals, this phenomenon literally propelled high voltage charge out into the surrounding space where it was felt as a stinging sensation. The stings lasting for a small fraction of a second, the instant of switch closure. But Tesla believed that these strange effects were a simple effect of ionized shockwaves in the air, rather like a strongly ionized thunderclap.

Tesla devised a new series of experiments to measure the shockwave pressure from a greater distance. He required an automatic "trip switch". With this properly arranged, a more controlled and repetitious triggering of the effect was possible. In addition, this arrangement permitted distant observations which might cast more light on the shield-permeating phenomenon. Controlling the speed of the high voltage dynamo controlled the voltage. With these components properly adjusted, Tesla was able to walk around his large gallery spaces and make observations. Wishing also to avoid the continuous pressure barrage and its stinging sparks, Tesla shielded himself with several materials. The arrangement of rapidly interrupted high voltage direct currents resulted in the radiation of stinging rays, which could be felt at great distances from their super-sparking source. In fact, Tesla felt the stings right through the shields! Whatever had been released from the wires during the instant of switch closure,

successfully penetrated the shields of glass and of copper. It made no difference; the effect permeated each substance as if the shield were not there at all. Here was an electrical effect that communicated directly through space without material connections. Radiant electricity!

In these several new observations, the phenomenon was violating electrostatic charge principles experimentally established by Faraday. Projected electrostatic charges normally spread out over the surface of a metallic shield; they do not penetrate metal. This effect had certain very non-electrical characteristics. Tesla was truly mystified by this strange new phenomenon, and searched the literature for references to its characteristics. No such reference was found, except in the surreptitious observations of two experimenters. In one case, Joseph Henry observed the magnetization of steel needles by a heavy spark discharge. The extraordinary feature of this observation (1842) lay in the fact that the Leyden jar, whose spark apparently produced the magnetizations, stood on the upper floor of an otherwise electrically impervious building. Brick walls, thick oak doors, heavy stone and iron flooring, tin ceilings. Moreover, the steel needles were housed in a vault in the cellar. How did the spark affect such a change through such a natural barrier? Dr. Henry believed that the spark had released special "light-like rays", and these were the penetrating agencies responsible for the magnetizations.

A second such account (1872) occurred in a high school building in Philadelphia. Elihu Thomson, a physics instructor, sought to make the sparks of a large Ruhmkorff Spark Coil more visible for his next lecture. Attaching one pole of the coil to a cold water pipe, and reactivating the coil, *Thomson was thrilled to find that the nature* of the spark had changed from blue to white. Wishing to amplify this effect, Thomson attached the other pole to a large

metal tabletop. Again reactivating the coil produced a shrieking silver-white spark, entirely visible to any whom sat in the last row. Wishing to show this to a colleague, Edwin Houston, Thomson made for the door and was abruptly stopped. Touching the brass knob on the otherwise insulated oak door, Thomson received an unexpected sizzling shock. Turning off the Ruhmkorff Coil, Thomson found it possible to stop the effect. Calling for Edwin, he summarized what had occurred. Then turning the unit back on again, the stinging charge effects returned. The two gentlemen ran throughout the huge stone, oak, and iron building with insulated metal objects now. Each touch of a penknife or screwdriver to anything metallic, however distant from the coil or insulated from the floor, produced long and continuous white sparks. The account was written up as a short article in *Scientific American* later in the same year.

In studying each of these two prior observations, events each separated by some thirty years, Tesla perceived an essential unity with that of his own discovery. Each observation was perhaps a slight variant of the very same phenomenon. Somehow accidentally, each experimenter had managed to produce the explosive supercharging effect. In the case of Dr. Henry, the explosive bursts occurred in a single flash, electrostatic machines being used to accumulate the initial charge. The second case was peculiar, since it evidenced the sustained and continuous production of super-charging effects. The effect was rare because it obviously required very stringent electrical parameters. Tesla deduced this from the simple fact that the effect was so infrequently observed by experimenters the world over. In addition, he was quick to remark concerning the anomalous attributes attached to the phenomenon. Tesla knew that, despite the extremely penetrating effects in each case, he had secured the only means for achieving the "complete" and

maximum manifestation of supercharging. His was an apparatus with no equal, capable of releasing an aspect of the electrostatic field which others very apparently had .not.

Though discovered by Tesla in 1889, the preliminary observation of this effect was published after an intensive battery of investigations. The "Dissipation of Electricity", published just prior to Christmas of 1892, is the pivotal Tesla lecture. This is the departure point in which Tesla abandons research and development of high frequency alternating current. Divorcing himself from the field entirely, Tesla describes the shockwaves and other effects of IMPULSES. In addition to those physical sensations, which he describes in characteristic understatement, Tesla also enlarges upon the "gaseous" aspects associated with the phenomena. He observed that the abruptly charged wires in his experiments projected a strange gaseous stream when immersed in an oil bath. A phenomenon, which he once thought due entirely to wire-adsorbed gases, he found that the effect could be so continuously produced from a single wire that no volume of ordinary adsorbed gas could supply the flow. Indeed, he was able to produce streams of this kind in oil, which so powerfully projected from charged wire ends that they visibly depressed the oil into a hole, some two inches in depth! Tesla began to realize the true nature of the fine issuing "gas" which projected from wire ends immersed in oil.

He now prepared an extensive series of tests in order to determine the true cause and nature of these shocking air pulses. In his article, Tesla describes the shield permeating shocks as "soundwaves of electrified air". Nevertheless, he makes a remarkable statement concerning the sound, heat, light, pressure, and shock which he sensed passing directly through copper plates. Collectively, they "imply the presence of a medium of gaseous structure,

that is, one consisting of independent carriers capable of free motion". Since air was obviously not this "medium", to what then was he referring? Further in the article he clearly states that "besides the air, another medium is present".

Through successive experimental arrangements, Tesla discovered several facts concerning the production of his effect. First, the cause was undoubtedly found in the abruptness of charging. It was in the switch closure, the very instant of "closure and break", which thrust the effect out into space. The effect was definitely related to time, IMPULSE time. Second, Tesla found that it was imperative that the charging process occurred in a single impulse. No reversal of current was permissible, else the effect would not manifest. In this, Tesla made succinct remarks describing the role of capacity in the spark radiative circuit. He found that the effect was powerfully strengthened by placing a capacitor between the disrupter and the dynamo. While providing a tremendous power to the effect, the dielectric of the capacitor also served to protect the dynamo windings.

The effect could also be greatly intensified to new and more powerful levels by raising the voltage, quickening the switch "make-break" rate, and shortening the actual time of switch closure. Thus far, Tesla employed rotating contact switches to produce his unidirectional impulses. When these mechanical impulse systems failed to achieve the greatest possible effects, Tesla sought a more "automatic" and powerful means. He found this "automatic switch" in special electrical arc dischargers. The high voltage output of a DC generator was applied to twin conductors through his new arc mechanism, a very powerful permanent magnet sitting crosswise to the discharge path. The discharge arc was automatically and continually "blown out" by this magnetic field.

## ***The Rosetta Stone***

Imperative toward obtaining the desired rare effect, the capacitor and its connected wire lines had to be so chosen as to receive and discharge the acquired electrostatic charge in unidirectional staccato fashion. The true Tesla circuit very much resembles a pulse jet, where no backpressure ever stops the onrushing flow. Electrostatic charge rises to a maximum and is discharged much more quickly. The constant application of high voltage dynamo pressure to the circuit insures that continual successions of "charge-rapid discharge" are obtained. It is then and only then that the Tesla Effect is observed. Pulses literally flow through the apparatus from the dynamo. The capacitor, disrupter, and its attached wire lines, behave as the flutter valve.

The high voltage dynamo remains the true electrostatic source in the apparatus. This was a fact well appreciated by Tesla, who disliked the painful radiant effects proceeding into space. It was evident that the dynamo had somehow been modified by the addition of these "pulsing valve" circuits. The dynamos being used provided deadly voltages, capable of killing a man. The valve circuits were forcing a strange radiance of those deadly field energies. Somehow, the dynamo energy was being expanded into space with dangerous and painful force. But how? By what mysterious and provocative means was this condition established? The result of this experimental series fixed a new concept in Tesla's mind. Tesla had of course realized the implications of his mysterious shocking-field effect. This was radiant electricity.

Tesla first conducted elaborate and extensive investigations in order to comprehend the exact nature of this new electrical effect. Tesla realized that this strange "shocking field" actually radiated through space from the impulse apparatus. If this was electrostatic energy, it was more intense and more penetrating than any

electrostatic field he had ever observed. If this was merely a "stuttered" electrostatic field, why then was its strength so very intensified? Tesla began to believe that he had discovered a new electrical force, not simply a treatment of an existing force. It is for this reason that he often described the effect as "electrodynamic" or "more electrostatic".

By properly adjusting the inherent circuit parameters, Tesla learned how to produce an extremely rapid series of unidirectional impulses on demand. When the impulses were short, abrupt, and precise in their successions, Tesla found that the shocking effect could permeate very large volumes of space with apparently no loss of intensity. He also found that the shocking effect penetrated sizable metal shields and most insulators with ease. Developing a means for controlling the number of impulses per second, as well as the intermittent time intervals between each successive impulse, he began discovering a new realm of effects. Each impulse duration gave its own peculiar effects. Able to feel the stinging shocks, though shielded at a distance of nearly fifty feet from his apparatus, Tesla recognized at once that a new potential for electrical power transmission had been revealed to him. Tesla was first to understand that electrical shock waves represented a new means for transforming the world, even as his Polyphase system had done.

Tesla fully intended to disclose his discoveries to the world at large. Radiant electricity had special characteristics of which the scientific world had no knowledge. Working with a simple but powerful embodiment of his original apparatus, Tesla found that radiant electricity could induce powerful electrical effects at a distance. These effects were not alternations, not alternating waves. They were longitudinal waves, composed of successive shocking waves. The advance of

each shocking wave, followed by short neutral zones together comprised the radiant field. Vectorial components of these shockwave successions were always unidirectional. The stuttering shockwaves were capable of forcing charges in the direction of their propagation.

Objects placed near this device became powerfully electrified, retaining a singular charge sign for many minutes after the magnetic discharger had been deactivated. Tesla found it possible to amplify these single charge effects by a simple asymmetrical alignment of the magnetic discharger. By placing the magnetic discharger closer to one or the other side of the charging dynamo, either force positive or force negative vectors could be selected and projected. Thus, charge could be projected into or drawn from any object in the field space. This was a new electrical force. Tesla realized more than ever that he was in unknown territory. The fact that these radiant forces traveled as light-like rays distinguished them from the electromagnetic waves of Maxwell.

Tesla wished to determine the effect of gradually decreased impulse durations, a job that required the greatest skill and precaution. Tesla knew that he would be exposing himself to mortal danger. Controlling the rapidity of current blowout in the magnetic DC arc, Tesla released a new spectrum of light-like energies throughout his large gallery space. These energetic species were like no other which the world has since seen. Tesla found that impulse duration alone defined the effect of each succinct spectrum. These effects were completely distinctive, endowed with strange additional qualities never purely experienced in Nature. Trains of impulses, each exceeding 0.1 millisecond duration, produced pain and mechanical pressures. In this radiant field, objects visibly vibrated and even moved as the force field drove them along. Thin wires, exposed to sudden

bursts of the radiant field, exploded into vapor. Pain and physical movements ceased when impulses of 100 microseconds or less were produced.

With impulses of 1.0 microsecond duration, strong physiological heat was sensed. Further decreases in impulse duration brought spontaneous illuminations capable of filling rooms and vacuum globes with white light. At these impulse frequencies, Tesla was able to stimulate the appearance of effects, which are normally admixed among the electromagnetic energies inherent in sunlight. Shorter impulses produced cool room penetrating breezes, with an accompanying uplift in mood and awareness. There were no limits in this progression toward impulses of diminished duration. None of these impulse energies could be duplicated through the use of high frequency harmonic alternations. Few could reproduce these effects because so few understood the absolute necessity of observing those parameters set by Tesla. These facts have been elucidated by Eric Dollard, who also successfully obtained the strange and distinct effects claimed by Tesla.

By 1890, after a period of intense experimentation and design development, Tesla summarized the components necessary for the practical deployment of a radiant electrical power distribution system. Tesla had already discovered the wonderful fact that impulse durations of 100 microseconds or less could not be sensed and would do no physiological harm. He planned to use these in his power broadcast. Furthermore, shocking waves of 100 microsecond duration passed through all matter, a fitting form of electrical energy to broadcast throughout a power-needy city.

Tesla made a most startling discovery the same year, when he placed a long single turn copper helix near his magnetic disrupter. The coil, some two feet in length, did not behave as did solid copper pipes and

other objects. The thin-walled coil became ensheathed in an envelope of white sparks. Undulating from the crown of this coil were very long and fluidic silvery white streamers, soft discharges that appeared to have been considerably raised in voltage. These effects were greatly intensified when the helical coil was placed within the disrupter wire circle. Inside this "shockzone", the helical coil was surrounded in a blast, which hugged onto its surface, and rode up the coil to its open end. It seemed as though the shockwave actually pulled away from surrounding space to cling to the coil surface, a strange attractive preference. The shockwave flowed over the coil at right angles to the windings, an unbelievable effect. The sheer length of discharges leaping from the helix crown was incomprehensible. With the disrupter discharge jumping 1 inch in its magnetic housing, the white flimmering discharges rose from the helix to a measured length of over two feet. This discharge equaled the very length of the coil itself! It was an unexpected and unheard of transformation.

Here was an action more nearly "electrostatic" in nature, although he knew that academes would not comprehend this term when used in this situation. Electrostatic energy did not fluctuate, as did his shockwaves. The explosive shockwave had characteristics unlike any other electrical machine in existence. Yet Tesla stated that the shockwave, during the brief instant in which it made its explosive appearance, more nearly resembled an electrostatic field than any other known electrical manifestation. Just as in electrostatic friction machines, where current and magnetism are negligible, a very energetic field component fills space in radiating lines. This "dielectric" field normally launches *through space in a slow growth as charges are gathered*. Here was a case where a DC generator provided the high voltage. This voltage charged an insulated hoop of

copper, growing to its maximum value. If all values in the circuit were properly balanced, in the manner prescribed by Tesla, a sudden charge collapse would then occur. This collapse was necessarily very much shorter than the interval required to charge the hoop. The collapse comes when the magnetic disrupter extinguishes the arc. If the circuit is properly structured, no backrush alternations ever occur.

This unidirectional succession of charge-discharge impulses causes a very strange field to expand outward, one, which vaguely resembles a "stuttering" or "staccato" electrostatic field. But these terms did not satisfactorily describe the conditions actually measured around the apparatus, a powerful radiant effect exceeding all expectable electrostatic values. Actual calculation of these discharge ratios proved impossible. Implementing the standard magneto-inductive transformer rule, Tesla was unable to account for the enormous voltage multiplication effect. Conventional relationships failing, Tesla hypothesized that the effect was due entirely to radiant transformation rules, obviously requiring empirical determination. Subsequent measurements of discharge lengths and helix attributes provided the necessary new mathematical relationship.

He had discovered a new induction law, one where radiant shockwaves actually auto-intensified when encountering segmented objects. The segmentation was the key to releasing the action. Radiant shockwaves encountered a helix and "flashed over" the outer skin, from end to end. This shockwave did not pass through the windings of the coil at all, treating the coil surface as an aerodynamic plane. A consistent increase in electrical pressure was measured along the coil surface. Indeed, Tesla stated that voltages could often be increased at an amazing 10,000 volts per inch of axial coil surface. This meant that a 24-inch coil could absorb radiant

shockwaves, which initially measured 10,000 volts, with a subsequent maximum rise to 240,000 volts! Such transformations of voltage were unheard with apparatus of this volume and simplicity. Tesla further discovered that the output voltages were mathematically related to the resistance of turns in the helix. High resistance meant higher voltage maxima.

He began referring to his disrupter line as his special "primary", and to the helical coil placed within the shockzone, as his special "secondary". But he never intended anyone to equate these terms with those referring to magneto-electric transformers. This discovery was indeed completely different from magneto-induction. There was a real and measurable reason why he could make this outlandish statement. There was an attribute which completely baffled Tesla for a time. Tesla measured a zero current condition in these long copper secondary coils. He determined that the current, which should have appeared, was completely absent.

Pure voltage was rising with each inch of coil surface. Tesla constantly referred to his "electrostatic induction laws", a principle which few comprehended. Tesla called the combined disrupter and secondary helix a "Transformer".

Tesla Transformers are not electromagnetic devices; they use radiant shockwaves, and produce pure voltage without current. Each transformer conducted a specific impulse duration with special force. Therefore each had to be "tuned" by adjusting the disrupter to that specific impulse duration. Adjustments of arc distance provided this control factor. Once each transformer was tuned to its own special response rate, impulses could flow smoothly through the system like gas flowing in a pipe.

Finding that gas-dynamic analogies and applications indeed provided him with a consistent record of successful assessments

in these regards, Tesla began considering whether or not the white flame discharges, so different from anything he had ever seen, might not be a gaseous manifestation of electro-static force. There were certainly abundant experimental instances in which a purely gaseous nature, so unlike anything electrical, was being clearly made manifest. The manner, in which the radiant shockwave traveled over the wire coilings in white flimmering lamniar streams, brought a new revolution in thought. Voltage pulses traversed the secondary surface like a gas pulse under increasing constriction. Until reaching the free end of the coil, these gaseous pulses flowed over the copper surface rather than through it. Tesla referred to this specific manifestation as the "skin effect". In this the discharge greatly resembled the manner of gases in motion over surfaces.

Furthermore, whenever a metal point was connected to the upper terminal of one of his Transformers, the stream became more directive. It behaved just like a stream of water in a pipe. When the white flimmering stream was directed at distant metal plates, it produced electronic charges. This charge production could be measured as amperage, "current", at the reception site. In transit however, no such amperage existed. Amperage appeared only when intercepted. Eric Dollard has stated that the space surrounding Tesla Impulse Transformers so surges with these streams that the "interception current" can reach several hundred or even thousands of amperes. But of what was this mysterious stream composed? Tesla struggled with the doubt that these discharge phenomena might be ordinary electricity behaving in extraordinary ways. But did electricity indeed have a smooth, soft, and flimmering nature? The electricity with which he was familiar was shocking, hot, burning, deadly, piercing, stinging, all the attributes of an irritant. But this discharge phenomenon



was, whether cool or warm to the touch, soft and gentle. It would not kill.

Even the manner, in which the pulse exploded as bright white discharges of greatly transformed voltage, suggested the way in which gases behave when released from their confinements under pressure. These reflective meditations convinced Tesla that this effect was not purely electrical in nature. Closely examining the white flames, Tesla realized why there was no measurable "electrical current" at the crown of these activated coils. The normal heavy charge carriers, electrons, could not travel as quickly as the radiant pulse itself. Choked in the metallic lattice of the coil, electrons became immobile. No electron current moved through the coil at all. The radiant pulse, which moved over the coil surface, was therefore not electronic in nature.

Additionally, Tesla discovered an amazing phenomenon, which removed all doubt concerning the true nature of energetic carriers at work in his apparatus. Tesla arranged a very heavy U-shaped copper bus bar, connecting both legs directly to his disrupter primary. Across the legs of this U-shaped bus bar were placed several incandescent lamps. The arrangement was a very evident short circuit. The lamps were illuminated to a brilliant cold white light, while being shorted by a heavy copper shunt. Uncharacteristic of particulate current electricity, the bright but cold lamps revealed that another energetic current was indeed flowing through the "short-circuits".

Those who observed this experiment did not expect it to perform any function save the incineration of the disrupter circuit and possibly of the dynamo itself. Instead of this, witnesses beheld a marvel. The lamps lit to an uncommon brightness. In this simple demonstration, Tesla was illustrating but one of his many evidences. Electronic charges would prefer the least

resistant circuit, rejecting the incandescent bulbs for the copper path. The current in this situation chose to conform to a contradictory principle. Perhaps this was true because the currents were not electrical. Tesla repeatedly used this demonstration to evidence the "fractionation" of currents electronic, from currents neutral.

A single question remained, the answer to which would provide him with the essential information needed to create a new technology. What so separated or "fractionated" the diverse mobile carriers in his transformer? It was the geometric configuration of the coil, which inadvertently separated each component. Electrons were blocked from flowing through the wire length, while the radiant pulse was released over the coil surface as a gaseous pulse. Electrons should have drifted through the wire but, during each impulse period, were blocked by the line resistance. Thus, the gaseous mobile carriers were released to flow outside the wire, a pulse that traveled along the outer coil surface from end to end.

Here then was evidence that electrical discharges were indeed composed of several simultaneous mobile species. Tesla now comprehended why his first high frequency alternating currents never evidenced these powerful actions. It was the abruptness, the violence of the impulsive discharge, which gave free mobility to this unsuspected "gaseous" component. Impulses, unidirectional impulses, were the only means by which these potentials could be unlocked. Alternations were absolutely useless in this regard. Moreover, because alternations could not unleash the second gas-dynamic component, it remained an unusable and pitifully weak means. Tesla forever viewed his high frequency alternating devices as failed projects. This has great bearing on his highly critical views of Marconi and all the others like him who pursued high frequency alternating wave

radio. Tesla began to study a topic, which has found more enemies and critics than any this century. Tesla, with greatest interest now, began researching "the aether".

Tesla came to believe that dielectric fields were actually composed of aether streams. Theoretically then, one could derive limitless energy by trapping and conducting a naturally occurring dielectric field line. The problem was that no ordinarily accessible material could resist the aether enough to derive any momentum from it. With a stream so rare as to pass through all known materials, the kinetic energy inherent in dielectric field lines would remain an elusive energy source. Tesla believed he may have found the secret to tapping this energy, but it would not require an ordinary kind of matter. Tesla viewed voltage as streams of aether under various states of pressure. Raising these stresses could produce enormous xther streams, where the observed voltage would then be extremely high and luminous. This was the very condition which Tesla had come to believe had been established in his Transformers.

In fact, Tesla repeatedly stated that his Transformers effected powerful movements in the aether. In one truly mystifying experiment indicative of these comprehensions, Tesla describes the production of very rapid impulse trains with a subsequent production of "cool misty white streamers extending a yard into space". These were cool to the touch, and harmless. If electrical in nature, they would necessarily have been several million volts in potentials. Their harmlessness is coupled with their sinuous nature, one completely unlike electrical currents.

Indeed, to understand Tesla technology one must eliminate the notion that electrons are the "working fluid" in his radiant energy designs. With the lower coil end connected directly to the dynamo, high voltage aether stream were projected from

the upper terminal. When describing each of his relevant patents in this new technology, Tesla forever spoke of "lightlike rays" and "the natural medium". The first term refers to the tightly constricted aether streams, which are propelled from his Transformers along infinitesimal ray lines, and the latter refers to the all-pervading aether atmosphere in which his technology operated.

It is impossible to comprehend Teslian Technology apart from the controversial topic concerning the aether. Many analysts will reject the concept without first seeking out and discovering the proofs, which have been established by experimenters such as Eric Dollard. Tesla addressed the notion that aether streams were being pulled through his Transformers, drawn in at higher natural pressure, and accelerated in the sharp electrical discharge. As electrical systems, Tesla apparatus cannot completely be understood or explained. One must view Teslian Technology as a aether gas technology, one capable of being explained only through gas-dynamic analogues.

It was now easy to understand how such projected rays, aether gas streams under high pressure, could penetrate metals and insulators alike. These powerful rays often could penetrate certain materials with inexplicable efficiency. Electricity did not perform these wonders. Tesla also now understood why these discharge streams produced their smoothly hissing sounds, visibly appearing like gas jets under high pressure. Aether gas under pressure. Tesla was completely mystified. He had successfully released the mystery current, normally suppressed and bound in electronic charge carriers. Unidirectional impulsive discharges of high voltage and abrupt durations released them. What other potentials would aether gas technology release?

The original cylindrical coils were quickly replaced with cone shaped coils.

With these bizarre geometries, Tesla was able to focus the gas-dynamic component, which now rose up like a jet of hissing white light from the coil tip. Tesla recognized that these discharges, white spectacular and awe inspiring, actually represented lost power. A power broadcast station had to evenly disperse the energetic radiance in all directions. Flame-like discharges caused the available power to undulate in space. This would produce unpredictable power drops at great distances. Consumers would not receive a reliable and consistent stream of energy. If his Power Transformer was to operate with highest broadcast efficiency, these *flame-like* discharges necessarily had to be suppressed. But suppressing these excessive aether jets proved problematic.

Tesla found that the white flimmering streams were absorbed in large capacity volumes, masses in which the streams were absorbed, filtered, and expelled. The use of copper spheres atop his Transformers forced the streams sufficiently apart to suppress the white flame. Power was now evenly dispersed throughout space as required. But a new problem appeared. The copper spheres, being impacted by the high voltage streams which they were forced to now conduct, expelled electronic components. These appeared along with the radiance, producing truly dangerous conditions. The problem was stimulated by conduction, a case where the spherical copper ball was impacted throughout its volume. The white flimmering streams permeated the copper and expelled electrons. These contaminants concentrated their escape from the system as harmful, blue stinging dartlets. By comparison, the white *flame-like* discharge was a smooth and harmless glow.

Comparing the two species, Tesla recognized the difference in charge carriers. Tesla was once nearly killed when one such dartlet jumped three feet through the air and struck him directly over the heart. The

copper spheres had to be removed and replaced by another dispersion component. Metals were apparently of no utility in this case, being natural reservoirs of electrons. Tesla eventually suggested that metals manufactured electrons when impacted with these special flame-white currents, the carriers in the white flames becoming concentrated within the metallic lattice.

He had already observed how the very air near these transformers could be rendered strangely self-luminous. This was a light like no high frequency coil ever could produce, a corona of white brilliance, which expanded to ever enlarging diameters. The light from Tesla Transformers continually expands. Tesla described the growing column of light which surrounds any elevated line which has been connected to his transformers. Unlike common high frequency alternations, Tesla radiant energy effects grow with time. Tesla recognized the reason for this temporal growth process. There were no reversals in the source discharges, therefore the radiant energy would never remove the work performed on any space or material so exposed. As with the unidirectional impulse discharges, the radiant electric effects were additive and accumulative. In this respect, Tesla observed energy magnifications, which seemed totally anomalous to ordinary engineering convention.

It was easy to control the brilliance of a room by controlling the voltage in his transformers. The light from this sort of illumination was curiously bright to human perception, but nearly impossible to photograph on film. Tesla found it necessary to make long time exposures of his discharges before the faintest sort of streamers could be made visible. This strange inability to register photographically was contrasted against the brilliance perceived in the eyes, one which required delicate control. Tesla also designed, built, and utilized large globe lamps, which

required only a single external plate for receiving the radiant energies. However distantly placed from the radiant source, these lamps became brilliantly illuminated. Theirs was a brilliance approaching that of an arc lamp, and exceeding any of the conventional Edison filament lamps by several factors. It was also easy for Tesla to control the heat of any space. By controlling both the voltage and impulse duration of energy in his Transformers, Tesla could heat up a room. Cool breezes could also be arranged by appropriately setting the impulse duration.

The key to producing all aetheric action was to secure a means for actually effecting aetheric deviations, the very thing now possessed by Tesla alone. Sir Oliver Lodge stated that the only means for “getting at the aether” was “an electrical means”, but not one member of the Royal Society had been able to achieve this feat with the rare exception of Sir William Crookes. The Tesla method used aether to modify aether! The secret was separating the contaminants from the aether current at the very source of generation, a feat that he had achieved in his Transformers and magnetic arc disrupters.

Tesla used the violence of magnetically disrupted arc discharges to chaoticize electronic and aetheric carriers in metal conductors. Breaking the agglomerations that bind them together, each component was free to separate. This condition could not be achieved in arc discharges where currents were allowed to alternate. In such apparatus, the electronic carriers overwhelmed the release of aether and, while aether was present in the discharge, could never be separated from the composite current. The extraordinary efficiency of the magnetic arc disrupter in developing aetheric currents derived from several principles. Tesla saw that electrical current was really a complex combination of aether and electrons. When electricity was applied to the disrupter, a primary fractioning process

took place. Electrons were forcibly expelled from the gap by the strong magnetic influence. The aether streams, neutral in charge, remained flowing through the circuit however. The magnetic disrupter was his primary means for fractionating the electrons from the aether particles.

Aether particles were extremely mobile, virtually massless when compared with electrons, and could therefore pass through matter with very little effort. Electrons could not “keep up” with either the velocity or the permeability of aetheric particles. According to this view, aether particles were infinitesimals, very much smaller than electrons themselves.

The aetheric carriers contained momentum. Their extreme velocity matched their nearly massless nature, the product of both becoming a sizable quantity. They moved with superluminal velocity, a result of their incompressible and massless nature. Whenever a directed radiant matter impulse begins from some point in space, an incompressible movement occurs instantly through space to all points along that path. Such movement occurs as a solid ray, an action defying modern considerations of signal retardations in space. Incompressible raylines can move through any distance instantly. Should the path be 300,000 kilometers long, the impulse at the source end will reach that point as quickly as at all other points. This is superluminal velocity, instantaneous propagation. Radiant matter behaved incompressibly. In effect, this stream of radiant matter, virtually massless and hydrodynamically incompressible, was a pure energy! Radiant Energy.

Here was a distinct phenomenon, one that did not in fact manifest with other than impulse applications. Tesla alternately called these pure aetheric expulsions “radiant matter” and “radiant energy” Neutral in charge and infinitesimal in both mass and cross-section, Radiant Energy was unlike

any light seen since his work was concluded. If asked whether Radiant Energy can be compared with any existing physical item today, one would have to decline. We cannot draw parallels between Radiant Energy and the light energies with which science has long been preoccupied. But if light-like at all, Radiant Energy is possessed of qualities unlike any light, which we have learned to generate. And this is precisely

the problem. Tesla Technology is Impulse Technology. Without the disruptive, unidirectional IMPULSE, there are no Radiant Energy effects. Generating this Radiant Energy requires special energetic applications, applications of succinct and brief impulses. These impulses must be generated through the explosive agency of a disruptive discharge, just as Tesla prescribed.



## Chapter 3: Verifying Tesla's Secret

Before I return to the discussion of Ed Gray's cold electric circuits, I would like to take a little time to present evidence in support of Vassilatos' thesis.

I have been unsuccessful in my attempts to acquire a copy of Tesla's lecture, "The Dissipation of Electricity," so I have been unable to refer to that document to verify Vassilatos' analysis. However, I felt that his point of view was such a different way of looking at Tesla's work that I simply could not ask you, the reader, just to take it on faith that these are the facts. Therefore, I began researching the voluminous materials available on Tesla these days in an effort to find documentation to verify Vassilatos' thesis. In the large volume entitled *Nikola Tesla: Lectures, Patents and Articles*, I believe I was able to find more than enough evidence in Tesla's own writings to support Vassilatos' analysis of his work. First, this quote is taken from Tesla's article, "The Problems of Increasing Human Energy", that first appeared in *The Century Illustrated Monthly Magazine* in June of 1900:

Since I described these simple principles of telegraphy without wires, I have had frequent occasion to note that the identical features and elements have been used in the evident belief that the signals are being transmitted to considerable distances by Hertzian radiations. This is only one of the many" misapprehensions to which the investigations of the lamented physicist have given rise. About 33 years ago, Maxwell, following up on the suggestive experiment made by Faraday in 1845, evolved an ideally simple theory which intimately connected light, radiant heat, and

electrical phenomena, interpreting them as being all due to vibrations of a hypothetical fluid of inconceivable tenuity called the ether. No experimental verification was arrived at until Hertz, at the suggestion of Helmholtz, undertook a series of experiments to this effect. Hertz proceeded with extraordinary ingenuity and insight, but devoted little energy to the perfection of this old fashioned apparatus. The consequence was that he failed to observe the important function which the air played in his experiments and which I subsequently discovered. Repeating his experiments and reaching different conclusions, I ventured to point out this oversight. The strength of the proofs brought forward by Hertz in support of Maxwell's theory resided in the correct estimate of the rates of vibration of the circuits he used. But I ascertained that he could not have obtained the rates he thought he was getting. The vibrations with identical apparatus he employed are, as a rule, much slower, this being due to the presence of air which produces a dampening effect upon a rapidly vibrating electric circuit with high pressure as a fluid does upon a vibrating tuning fork. I have, however, discovered since that time, other causes of error, and I have long ago ceased to look upon his results as an experimental verification of the poetical concepts of Maxwell. The work of the great German physicist has acted as an immense stimulus to contemporary electrical research, but it has likewise, in a measure, by its fascination paralyzed the scientific mind, and thus hampered independent inquiry. Every new phenomenon, which was discovered, was made to fit the theory, and so, very often the truth has been unconsciously distorted.

N. TESLA.  
ELECTRIC CIRCUIT CONTROLLER.

(Application filed Apr. 19, 1896.)

(No Model.)

2 Sheets—Sheet L

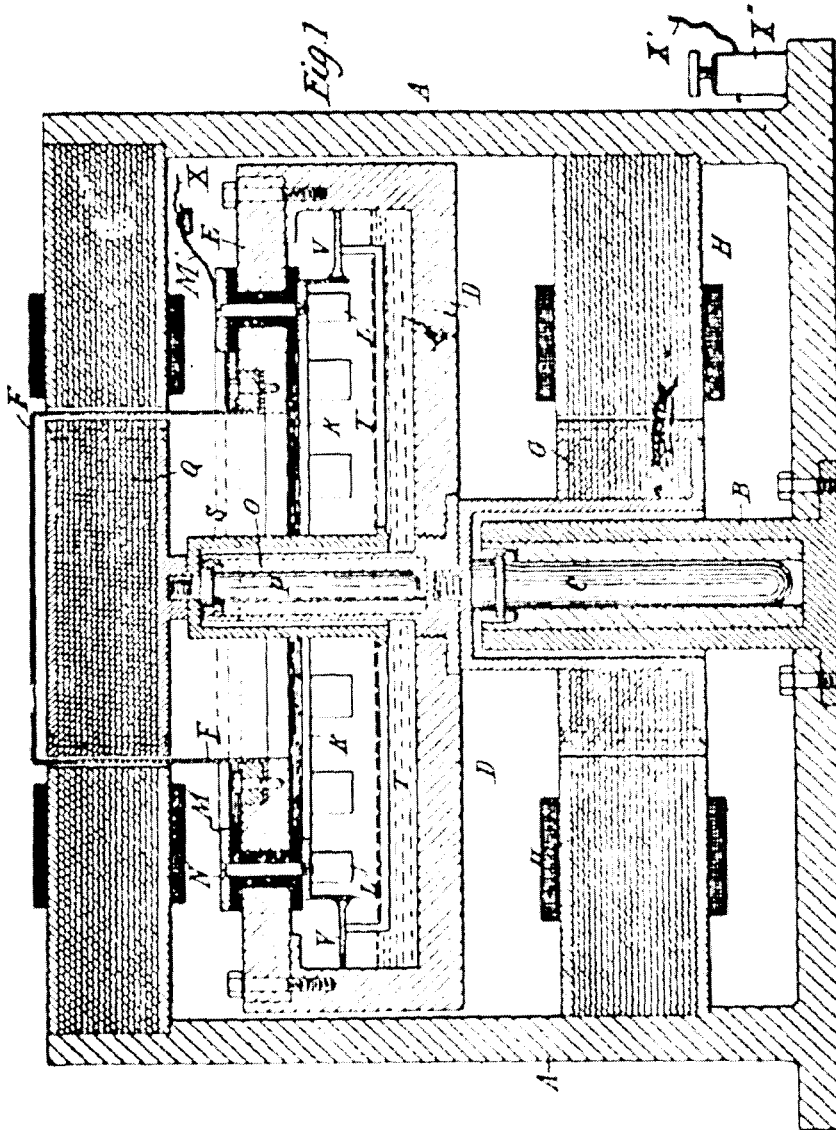

Witnesses:  
*Raphael Netter*  
*Benjamin Miller*

*Nikola Tesla, Inventor*  
*Res. Curtis & Agency*

Figure 15  
 Tesla's Mechanical Circuit Controller



## Verifying Tesla's Secret

Obviously, Tesla did not agree with the work of Helmholtz, Hertz, and Maxwell! For those readers who do not know who these gentlemen are, Hermann von Helmholtz laid the foundation for what is now known as the "First Law of Thermodynamics", which states that "Energy can be changed from one form to another, but it is neither created nor destroyed." James Clerk-Maxwell's equations are the backbone of modern electromagnetic theory, and Heinrich Hertz' supposed verification of Maxwell's work was deemed so important that they named the *measurement* of frequency after him. These esteemed gentlemen are pivotal personalities in the way electrical science is taught today. But, as we can see, Tesla dismissed them all as not being relevant to his experimental findings. In other words, if we follow this path back into the aethers, we must be willing to leave behind the ideas and limitations defined by the "First Law of Thermodynamics" and Maxwell's equations. We now will peer beyond the boundaries of these tools, and move into a completely different realm of study.

In the closing remarks from the article called "The *Transmission of Electric Energy Without Wires*," published in "The Electrical World and Engineer" in March of 1904, Tesla states:

When the great truth accidentally revealed and experimentally confirmed is fully recognized that this planet with all its appalling immensity is to electrical currents, virtually no more than a small metal ball, and by this fact many possibilities, each baffling imagination and of incalculable consequence, are rendered absolutely sure of accomplishment; when the first plan is inaugurated and it is shown that a telegraphic message, almost as secret and non-interferable as a *thought can be* transmitted to any terrestrial distance, the sound of the human voice, with all of its intonations and inflections, faithfully and instantly reproduced at any other point of

the globe, the energy of a waterfall made available for supplying light, heat or motive power, anywhere - on sea or land or high in the air - humanity will be like a ant heap stirred up with a stick: see the excitement coming!

Here it sounds as if Tesla really has something astonishing, that he understands it, and that he is expecting it to be unlimited. It sounds like something way beyond anything that had ever been done before. Even now, a hundred years later, we are only opening the door to some of these possibilities, particularly insofar as the transmission of the human voice is concerned. But we are certainly not there with regard to the availability of energy everywhere on land or sea or air. Clearly, Tesla is referring to something that has not been brought into full, public use.

What, then, was Tesla doing? What evidence do we have that Tesla was working on the kinds of systems that Mr. Vassilatos is talking about in his book?

First, there is the evidence that Tesla was working on circuits with spark-gaps in an attempt to achieve higher and higher spark-gap discharge speeds

Figure 15 represents one of Tesla's many patents called "Electric Circuit Controller." This patent is very interesting because it consists of two electric motors, each turning in opposite directions with a spark-gap in-between the two moving members. It is evident that Tesla was clearly trying to achieve faster speeds than he could get just by rotating one member. This is a clear example of Tesla's work on a mechanical spark-gap controller in an attempt to increase speed, as Vassilatos suggested in his book.

Figure 16 represents the only illustration in the Lectures, *Patents, Articles book of a* magnetically quenched spark-gap. However, it uses an electric magnet rather than a permanent magnet as referred to by Vassilatos. From this, it is clear that Tesla

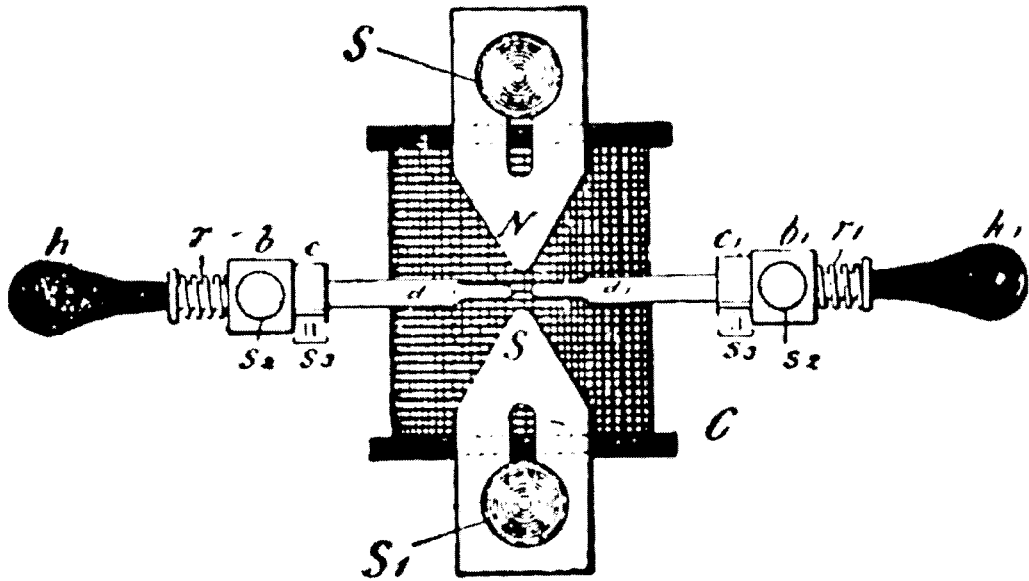

Figure 16  
Magnetically Quenched Spark

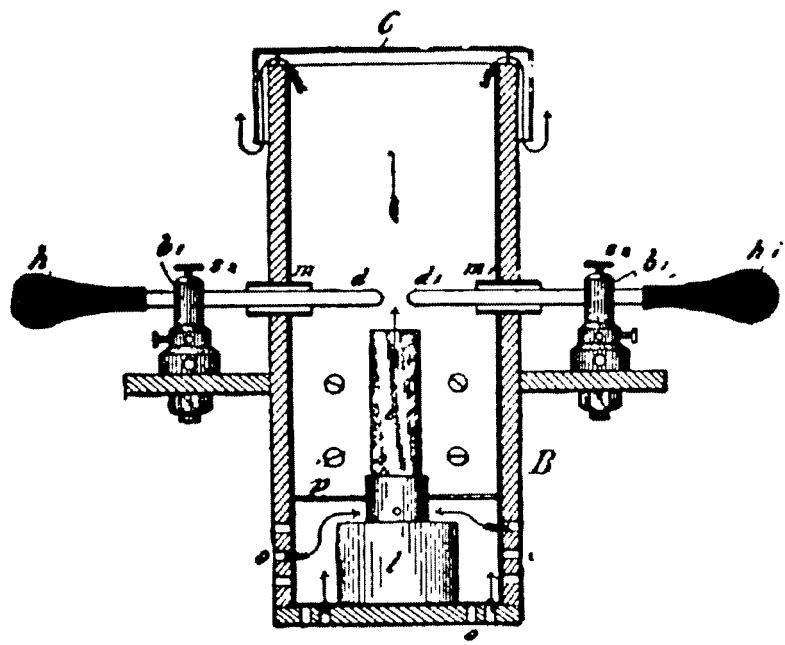

Figure 17  
Hot Air Quenched Spark

UNITED STATES PATENT OFFICE.

NIKOLA TESLA, OF NEW YORK N. Y.  
ELECTRICAL TRANSFORMER

SPECIFICATION forming part of Letters Patent No. 208,135, dated November 2, 1927.  
Application filed June 25, 1914. Serial No. 622,152. Renewed.

To all whom it may concern,  
Be it known that I, NIKOLA TESLA, a citizen of the United States residing at New York, in the county and State of New York, have invented certain new and useful improvements in Electrical Transformers, of which the following is a specification, reference being had to the drawings accompanying and forming a part of the same.  
10 The present invention relates to apparatus which I have designed and employed for the purpose of decreasing electrical currents of high potential, which is desirable in induction coils constructed on the principle hereinafter followed, in the manufacturing  
15 of such instruments and which is incapable of producing or generating electricity at least without special facilities of the character of the apparatus used and also in persons  
20 The improvement relates to a means for the transmission of electrical energy to a transformer or induction coil and a system for the transmission of electrical energy to a source of energy to which higher potential  
25 for transmission over the line has never been practically employed heretofore and the apparatus is constructed and arranged for the production of such a potential and consists  
30 in a means for the production of energy from the discharge of energy from the discharge of oscillations, but it is desirable to the end of transmitting energy from an induction coil to the secondary and secondary coils are connected in such a manner that the oscillations of the conductor of the primary coil and the secondary coil from the primary as the primary coil is from the effects of potential oscillations, the  
35 terminal point of the secondary coil being the most remote end of the secondary coil and oscillations thereof will be the least due to the difference of potential.  
The type of coil in which the last named features are present is the B' type and the  
40 end of the secondary coil is connected to the ground of the secondary and the other end of the secondary coil is connected to the ground of the primary coil or any other form of power source in the particular hereinafter specified.  
45 In constructing my improved transformer I employ a length of secondary which is approximately proportional to the wave length of the electrical disturbance in the secondary coil, based on the velocity of propagation of electrical disturbances through such circuit in general of such length that the potential at the terminal end of the secondary which is the more remote from the primary shall be at its maximum.  
50 In doing these things I connect one end of the secondary coil to the primary in the set-up circuit, and the other end to the earth through the ground circuit in general. I also connect the secondary coil to the primary in the set-up circuit and to the ground circuit in general through the ground circuit in general.  
55 To the accompanying drawings, Figure 1 is a plan view of the primary and secondary coils of an induction coil made in accordance with my invention.  
A is the secondary coil, wound upon an iron core generally spiral form.  
60 B is the primary, which is wound around the iron core and is connected to the terminal end of the secondary coil, and from this the current is taken to the ground circuit in general. The other terminal of the secondary is connected to earth and preferably also to the primary.  
65 When two coils are used in a system, one system in which the current is carried by a high potential and the other by a low potential, the high potential system will be constructed and connected in the same manner as the secondary coil in general, but the terminal of the first coil will be connected to the secondary and the other end to earth and to the local circuit or that which is connected to the primary of the first.  
70 It will be seen also that the B' type of coil is connected to the ground circuit in general by the ground circuit in general to obtain maximum efficiency and to obtain maximum efficiency in the secondary coil, the secondary coil is connected to the ground circuit in general and to the ground circuit in general.  
75 In doing these things I connect one end of the secondary coil to the primary in the set-up circuit, and the other end to the earth through the ground circuit in general. I also connect the secondary coil to the primary in the set-up circuit and to the ground circuit in general through the ground circuit in general.  
80 To the accompanying drawings, Figure 1 is a plan view of the primary and secondary coils of an induction coil made in accordance with my invention.  
A is the secondary coil, wound upon an iron core generally spiral form.  
85 B is the primary, which is wound around the iron core and is connected to the terminal end of the secondary coil, and from this the current is taken to the ground circuit in general. The other terminal of the secondary is connected to earth and preferably also to the primary.  
90 When two coils are used in a system, one system in which the current is carried by a high potential and the other by a low potential, the high potential system will be constructed and connected in the same manner as the secondary coil in general, but the terminal of the first coil will be connected to the secondary and the other end to earth and to the local circuit or that which is connected to the primary of the first.  
95 It will be seen also that the B' type of coil is connected to the ground circuit in general by the ground circuit in general to obtain maximum efficiency and to obtain maximum efficiency in the secondary coil, the secondary coil is connected to the ground circuit in general and to the ground circuit in general.  
100 In doing these things I connect one end of the secondary coil to the primary in the set-up circuit, and the other end to the earth through the ground circuit in general. I also connect the secondary coil to the primary in the set-up circuit and to the ground circuit in general through the ground circuit in general.

Figure 18  
Tesla's Electrical Transformer

was working with magnetically quenched spark gaps. This illustrates one of his many experiments to "blow-out" or quench a spark discharge. This mechanism is particularly interesting, because it was obviously designed for a DC spark. DC spark discharges do not start very easily. The presence of the spring-loaded handles on either side allow the spark mechanisms to be brought closer together to draw the initial spark by tapping one end or the other. Then they would spring back to their preset distances, enabling a DC spark discharge to begin under these very difficult conditions.

Figure 17 is an illustration showing another spark-gap mechanism. In this one, Tesla is blowing hot air across a spark discharge path and, as indicated in the accompanying text, there is also a magnetic field present. Since Tesla was using both hot air and a magnetic field with a spark-gap in this apparatus, clearly he was looking at a wide variety of possibilities to get more controllable spark discharges, and,

obviously, DC spark discharges with high voltage.

The cover sheet for a patent called Electrical Transformer is shown in Figure 18. Tesla states that this is the invention that he plans to employ in constructing improved coils and a manner of using them for transmission of energy over long distances.

One of the illustrations from that patent (Figure 19) clearly shows that he has the construct that Vassilatos was talking about: just a few turns in the primary and a conical coil in the secondary. So all the structures that Vassilatos wrote about are

Figure 20 is an illustration from the Tesla patent called the *Art of Transmitting Electrical Energy Through the Natural Mediums*. The diagram in Figure 21 is an enlargement of a section of this illustration showing the same basic structure of source "B" powering a 2-turn primary with a spiral coil in the middle of it. This apparatus was designed for broadcasting energy to great distances, so it also includes connections to the ground and the sky. (E) is the connection to the earth, and (E) is what Tesla called an "elevated capacitance". This was the heart of the magnifying transmitter system that Tesla attempted to construct at Wardenclyffe, New York, in order to broadcast energy to all points on the planet.

What is interesting about this is the source for energizing the system "B". When you look at this diagram, "B", on the left, looks like the symbol for a simple generator. However, the following excerpt from the patent text expands on the idea of exactly what source "B" is:

In Figure 1, 'A' designates a primary coil forming part of a transformer and consisting generally of a few turns of stout cable of inappreciable resistance, the ends of which are connected to the terminals of a source of power for electrical oscillations diagrammatically represented by B'. This

P-254  
(No Model.)

N. TESLA,  
ELECTRICAL TRANSFORMER.

No. 593,138.

Patented Nov. 2, 1897.

2 Sheets—Sheet 1.

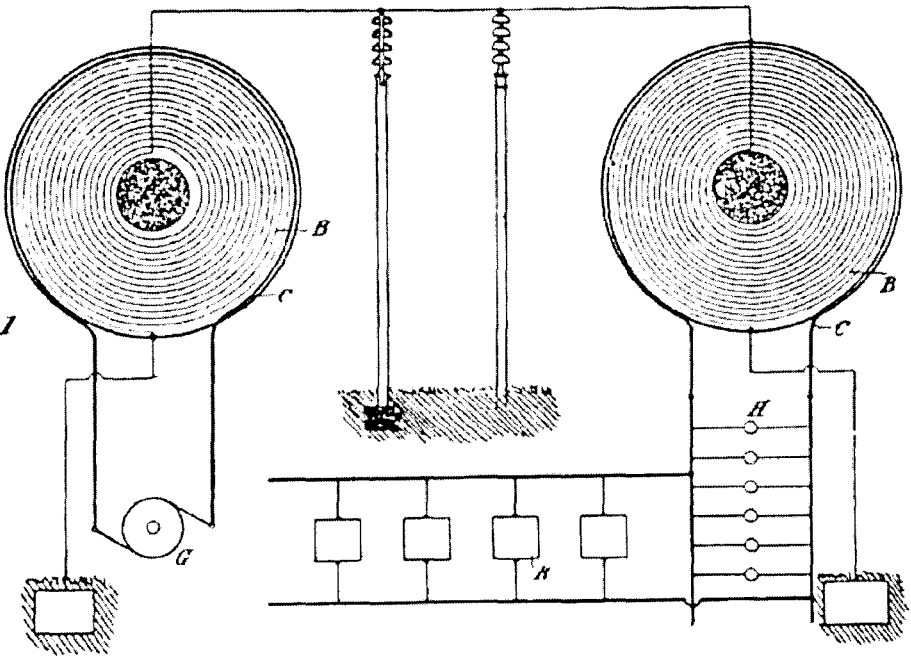

Fig. 1

WITNESSES  
G. B. Lewis,  
Edmund B. Stephenson,

INVENTOR  
Nikola Tesla  
Ken. Curtis V. Age  
ATTORNEY

(No Model.)

N. TESLA,  
ELECTRICAL TRANSFORMER.

No. 593,138.

Patented Nov. 2, 1897.

2 Sheets—Sheet 2

P-255

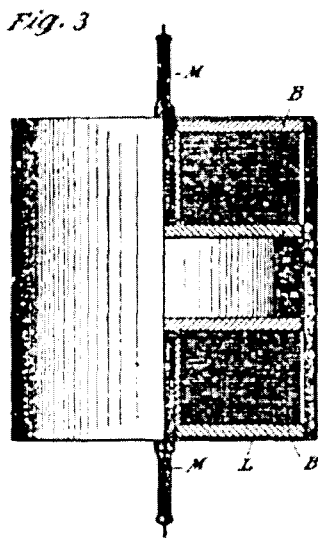

Fig. 3

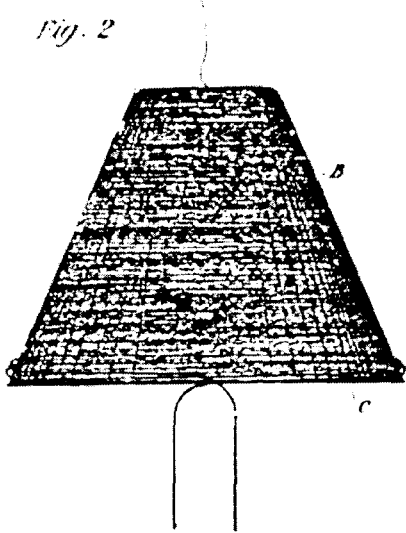

Fig. 2

WITNESSES  
G. B. Lewis,  
Edmund B. Stephenson

INVENTOR  
Nikola Tesla  
Ken. Curtis V. Age  
ATTORNEY

P-336

No. 787,412.

PATENTED APR. 18, 1905.

N. TESLA.

ART OF TRANSMITTING ELECTRICAL ENERGY THROUGH THE NATURAL  
MEDIUMS.

APPLICATION FILED MAY 16, 1900. RENEWED JUNE 17, 1902.

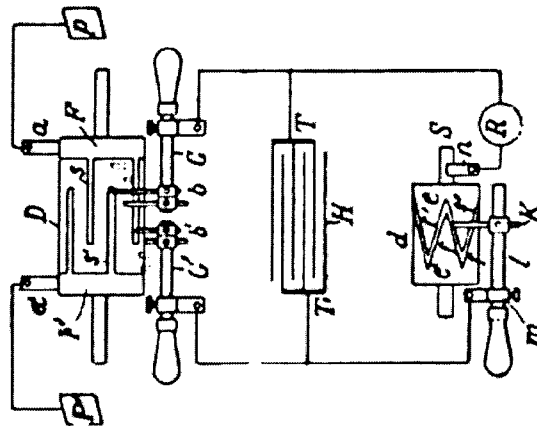

Fig. 2

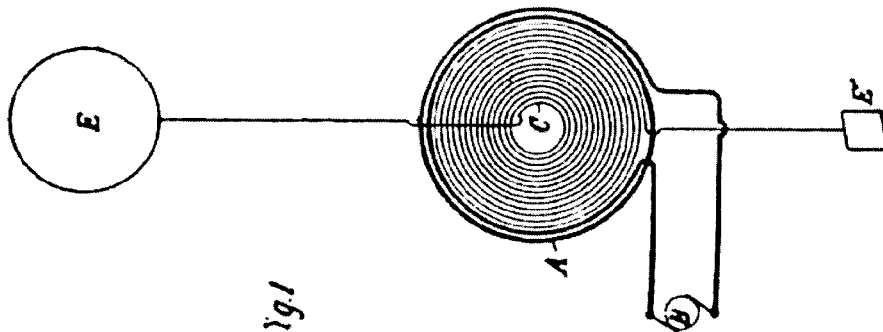

Fig. 1

Witnesses:  
*Raphael Kitter*  
*M. Lawson Dyer.*

*Nikola Tesla* Inventor  
by *New. Pap. Doolen* Attys

Figure 20  
Tesla's Magnifying Transmitter Illustration

high potential and discharged in rapid succession through the primary, as in a type of transformer invented by me.

In Figure 21, I refer to the image on the right side, as "Tesla's Magnifying Transmitter Illustration as Described in the Patent Text." This shows the capacitor and the disruptive spark-gap (in this case a magnetically quenched gap) so he could control the impulse characteristics the way he wanted.

Quoting from the text of this patent again, Tesla claims:

I have found it practicable to produce in this manner an electrical movement thousands of times greater than the initial.

So once again, he is talking about a tremendous gain in electrical *movement*. *This* is not just a gain in voltage like in ordinary transformers, but a gain in power.

Just prior to that quote on the same page, Tesla states:

These adjustments and relations being carefully completed and other constructive features indicated rigorously observed, the electrical movement produced in the secondary system by the inductive action of the primary, 'A', will be enormously magnified...

Tesla obviously believed, and stated repeatedly, that this system was capable of producing more energy out than he was putting in. Today, that concept is referred to as "Free Energy."

For more evidence that Vassilatots' analysis is correct, I refer back to the Lectures, Patents, Articles book. On page L112, (Figure 22) you can see "On the Apparatus and Method of Conversion." Illustrated here is a generator that can produce alternating currents into the circuits on the left and direct currents into the circuits on the right.

Figure 23 is a close up view of the direct current side. In the middle image, Tesla is taking direct current from the main

generator and running it through another apparatus that, as the text tells us, raises the DC voltage even higher. The circuit then charges a capacitor and discharges it through a magnetically quenched spark gap to run light bulbs and other apparatus.

This is direct evidence, in Tesla's published writings, that he was working with all of the components described by Vassilatots. True, he obscures them in a collection of other possibilities, but the essential elements are all present and explicitly defined.

Add to this, the following astonishing statement by Tesla taken from "The Problems of Increasing Human Energy" in the June, 1900 issue of Century Magazine (page A145):

Whatever electricity may be, it is a fact that it behaves like an incompressible fluid and the earth may be looked upon as an immense reservoir of electricity....

Considering that Nikola Tesla is the inventor of the polyphase electrical distribution system used all over the world today, it is astonishing that he states that he does not know what electricity is, but that it definitely acts like a fluid under pressure! This understanding of electricity is, of course, completely outside the accepted view.

Tesla's statement that electricity behaves like an incompressible fluid only begs the question: What fluid is he referring to? Could this be one of Tesla's cryptic references to ether gas as Vassilatots suggests?

From the text of the same article, on page A148, are these other relevant statements:

Finally, however, I had the satisfaction of accomplishing the task undertaken by the use of a new principle, the virtue of which is based on the marvelous properties of the electrical condenser.

One of these is that it can discharge or

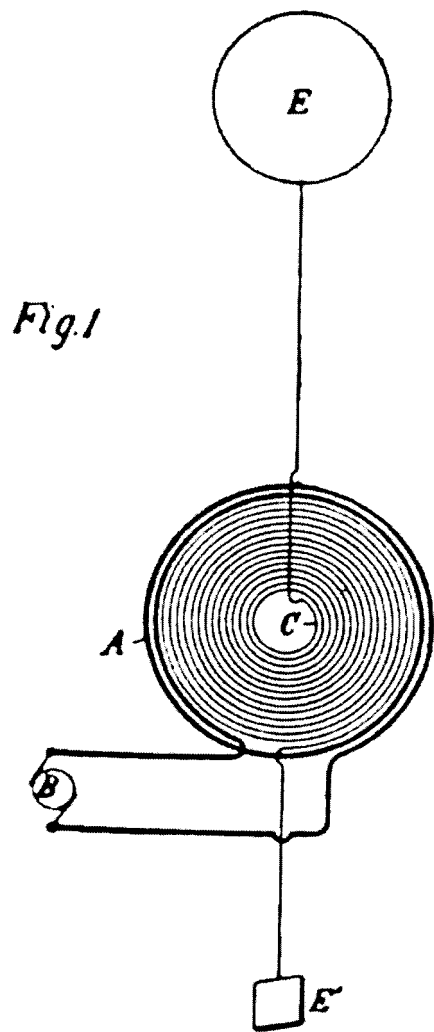

Tesla's Magnifying Transmitter Illustration

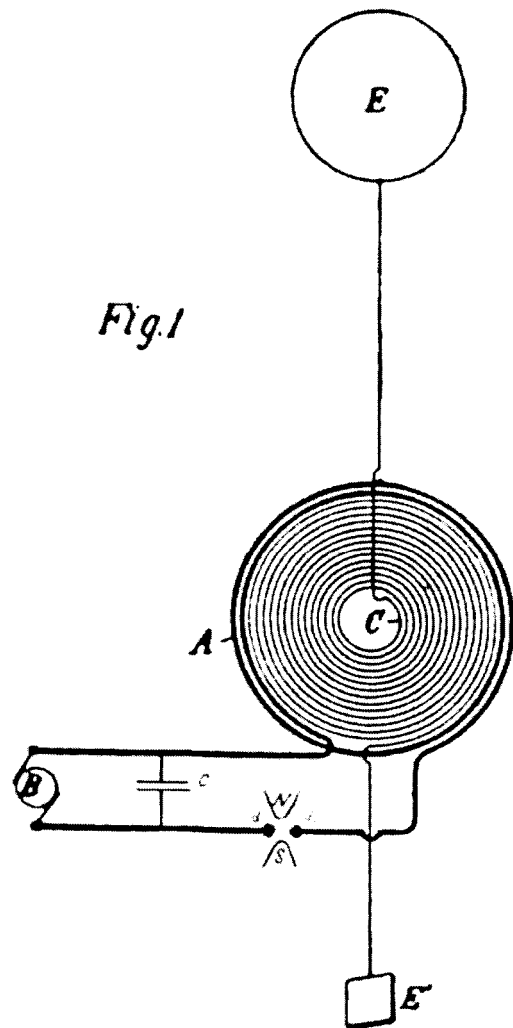

I Tesla's Magnifying Transmitter Illustration  
as Described in the Patent Text

**Figure 21**  
Tesla's Magnifying Transmitter as Described in the Patent

should possess, besides instructive, also entertaining features and as such, a simple experiment, such as the one cited, would not go very far towards the attainment of the lecturer's aim. I must therefore choose another way of illustrating, more spectacular certainly, but perhaps also more instructive. Instead of the frictional *machine* and Leyden jar, I shall avail myself in these experiments, of an induction coil of peculiar properties, which was described in detail by me in a lecture before the London Institution of Electrical Engineers, in Feb. 1892. This induction coil is capable of yielding currents of enormous potential differences, alternating with extreme rapidity. With this apparatus I shall endeavor to show you three distinct classes of effects, or phenomena, and it is my desire that each experiment, while serving for the purposes of illustration, should at the same time teach us some novel truth, or show us some novel aspect of *this* fascinating science. But before doing this, it seems proper and useful to dwell upon the apparatus employed, and method of obtaining the high potentials and high-frequency currents which are made use of in these experiments.

#### ON THE APPARATUS AND METHOD OF CONVERSION.

These high-frequency currents are obtained in a peculiar manner. The method employed was advanced by me about two years ago in an experimental lecture before the American Institute of Electrical Engineers. A number of ways, as practiced in the

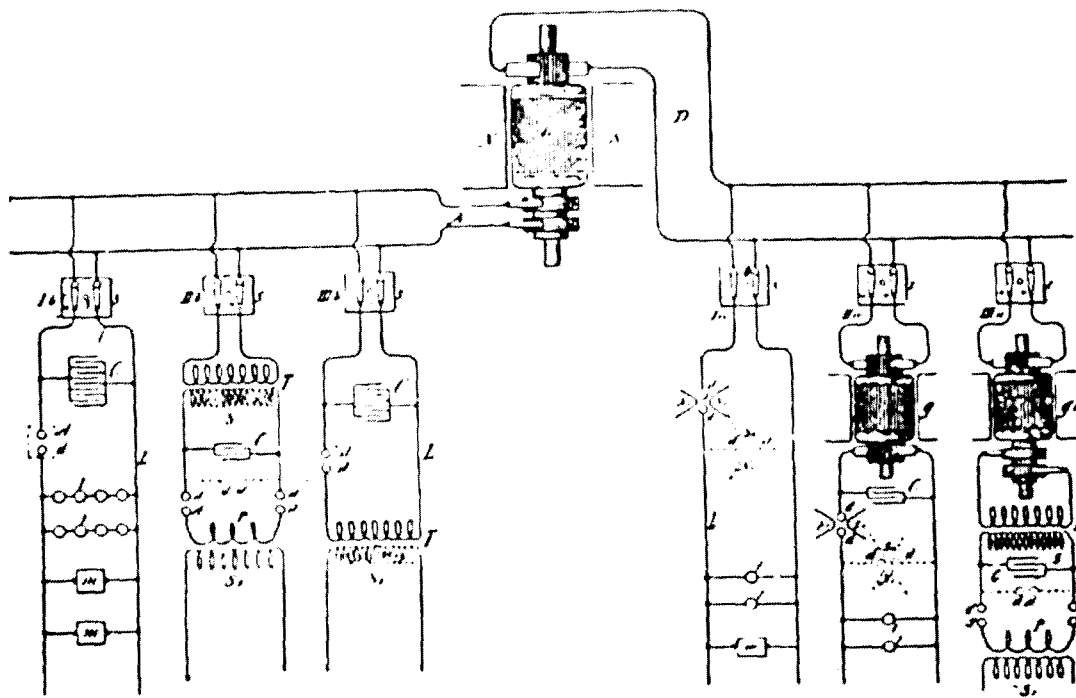

Fig. 1.

laboratory, of obtaining these currents either from continuous or low frequency alternating currents, is diagrammatically indicated in Fig. 1, which will be later described in detail. The general plan is to charge condensers, from a direct or alternate-current source, preferably of high-tension, and to discharge them disruptively while observing wellknown conditions necessary to maintain the oscillations of the current. In view of the

**Figure 22**

Illustration from a Tesla Lecture. February 1893



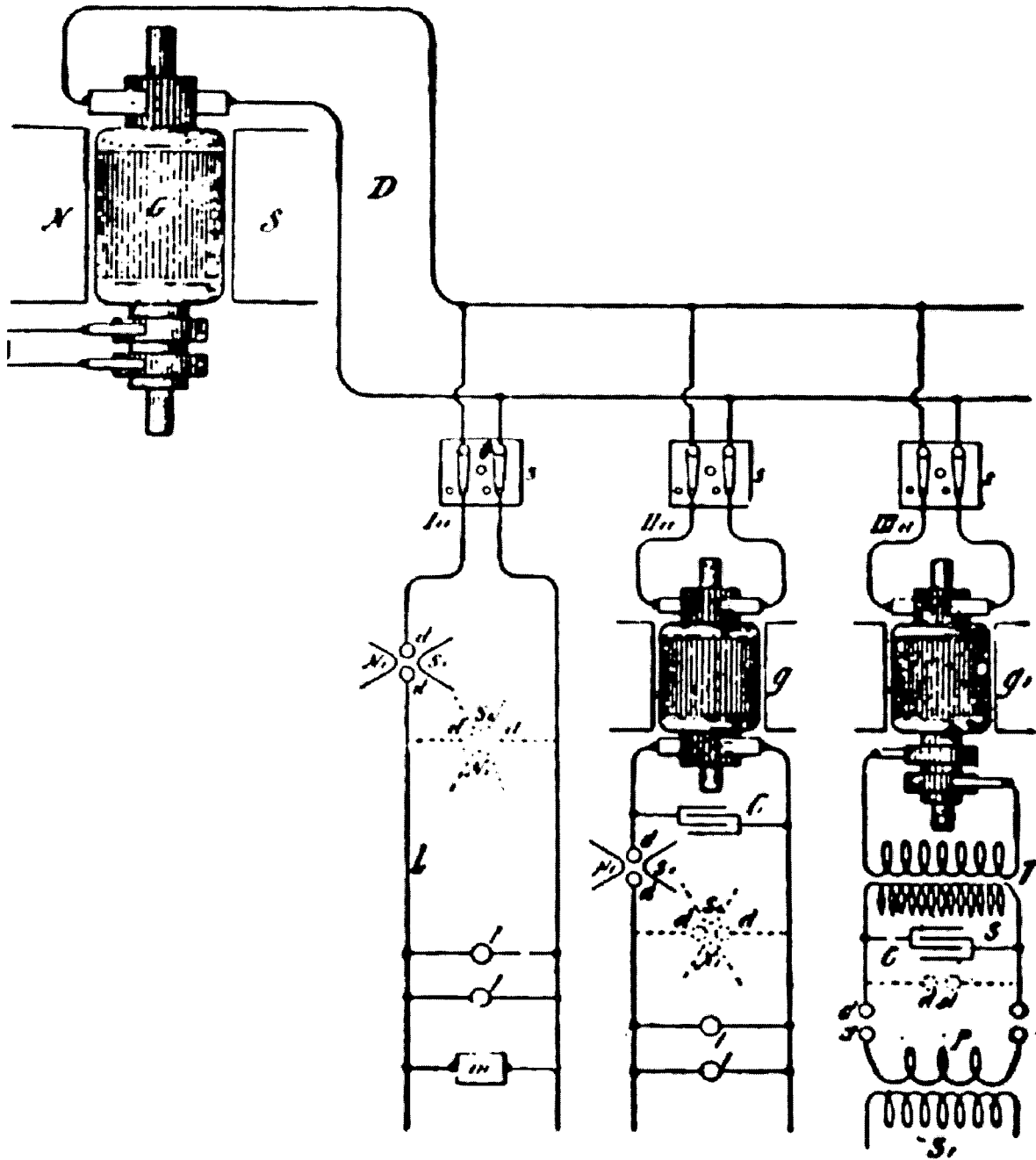

Figure 23  
Close-Up of "Method of Conversion"



**Figure 24**  
Radiant Energy Discharge

explode its stored energy in an inconceivably short time. Another of its properties, equally valuable, are that its discharge may vibrate at any rate desired up to many millions per second.

I arranged such an instrument so as to be charged and discharged alternately in rapid succession through a coil with a few turns of stout wire forming the primary of a transformer of induction coil.

Electrical effects of any desired character and of intensities undreamed of before are now easily producible by perfected apparatus of this kind, to which frequent reference has been made, and the essential parts of which are shown in Figure 6. For certain purposes, a strong inductive effect is required; for others the greatest possible suddenness; for others again, an exceptionally high rate of vibration or extreme pressure; while for certain other objects immense electrical movements are necessary.

So, now we have what I believe are ample and sufficient references in Tesla's

own words supportive of Vassilatou's main thesis that, indeed, Tesla was actively engaged in charging capacitors with high voltage DC sources; he was discharging them through magnetically quenched spark gaps; he was doing this at extremely high rates of vibration, even up to many millions of times per second, and finally, that this was the method of operating his "magnifying transmitter," the device that produced and captured what Tesla called "Radiant Energy."

The question is, in spite of all of this written evidence, do we have any direct proof that Tesla's Magnifying Transmitter produces a different form of electricity? To answer this question, I refer to Figure 24, a black and white version of the color image of the discharge from Eric Dollard's Magnifying Transmitter shown on the front cover of this book.

This photograph was taken by Alison Davidson in 1986 and was provided to me by Tom Brown in New Zealand. The wooden top of the coil is about 8 inches across. The voltage represented by this discharge is anyone's guess, but certainly must be approaching 400,000 volts. The other end of the coil is driving more than 4 amperes into the ground connection, measured on a radio frequency ammeter, and the entire system is drawing less than 2000 watts from the wall. This image shows an imperfectly purified etheric discharge, complete with "blue dartlets", just as Tesla described.

At this point I would like to add one more piece of eyewitness testimony concerning the nature of Tesla's radiant energy and cold electricity. On the same day Alison Davidson's photograph was taken, Tom Brown and I conducted an astonishing experiment. I picked up an ordinary filament light bulb and held the outer screw base in my right hand. Then I asked Tom to step over and touch the

bottom connection of the light bulb with his finger. As soon as he did this, the light bulb filament lit to full brightness in our hands. I was about six feet away from the magnifying transmitter and Tom was about eight feet away. I felt no unusual sensations at all, but I was quite startled. At that time I had no idea how really safe this form of energy is.

To summarize, Tesla accidentally discovered an electrostatic "super-charging" effect while trying to verify Hertz' discovery of electro-magnetic waves. After hundreds of experiments, he learned how to control and maximize this phenomenon. This led him to the discovery that electricity is made up of different components, that can be separated from each other, and that a pure, gaseous etheric energy can be fractionated away from the flow of electrons in a circuit designed to produce short duration, unidirectional impulses. When all the conditions were right, this gaseous, etheric energy would manifest itself as a spatially distributed voltage that would radiate away from the electrical circuit as a "light-like ray" that could charge other surfaces within the field.

From now on, I would like to refer to this phenomenon as "The Electro-Radiant Event" and summarize its characteristics as follows:

- The Electro-Radiant Event is produced when a high-voltage, direct current is discharged across a spark-gap and interrupted abruptly before any reversals of current can occur.
- This effect is greatly increased when the source of direct current is a charged capacitor.
- The Electro-Radiant Event leaves wires and other circuit components perpendicular to the flow of current.
- The Electro-Radiant Event produces a spatially distributed voltage that can be thousands of times higher than the initial spark discharge voltage.
- It propagates instantaneously as a longitudinal, electrostatic "light-like ray" that behaves similarly to an incompressible gas under pressure.
- Electro-Radiant effects are solely characterized by impulse duration and voltage drop in the spark gap.
- Electro-Radiant effects penetrate all materials and create "electronic responses" in metals like copper and silver. In this case, "electronic responses" means that an electrical charge will build up on copper surfaces exposed to Electro-Radiant emissions.
- Electro-Radiant impulses shorter than 100 microseconds are completely safe to handle and will not cause shock or harm.
- Electro-Radiant impulses shorter than 100 nanoseconds are cold and easily cause lighting effects in vacuum globes.

The "Electro-Radiant Event" is essentially the "gain mechanism" that Tesla discovered that is the basis of his Magnifying Transmitter. It is the foundation of his claim that he was able to create more energy in his output than it took to initiate it in his input.

## Summary of The Electro-Radiant Event

1. The Electro-Radiant Event is produced when a high-voltage, direct current is discharged across a spark gap and interrupted abruptly before any reversals of current can occur.
2. This effect is greatly increased when the source of direct current is a charged capacitor.
3. The Electro-Radiant Event leaves wires and other circuit components perpendicular to the flow of current.
4. The Electro-Radiant Event produces a spatially distributed voltage that can be thousands of times higher than the initial spark discharge voltage.
5. It propagates instantaneously as a longitudinal, electrostatic "light-like ray" that behaves similarly to an incompressible gas under pressure.
6. Electro-Radiant effects are solely characterized by impulse duration and voltage drop in the spark gap.
7. Electro-Radiant effects penetrate all materials and create "electronic responses" in metals like copper and silver. In this case, "electronic responses" means that an electrical charge will build up on copper surfaces exposed to Electro-Radiant emissions
8. Electro-Radiant impulses shorter than 100 microseconds are completely safe to handle and will not cause shock or harm.
9. Electro-Radiant impulses shorter than 100 nanoseconds are cold and easily cause lighting effects in vacuum globes.

Figure 25



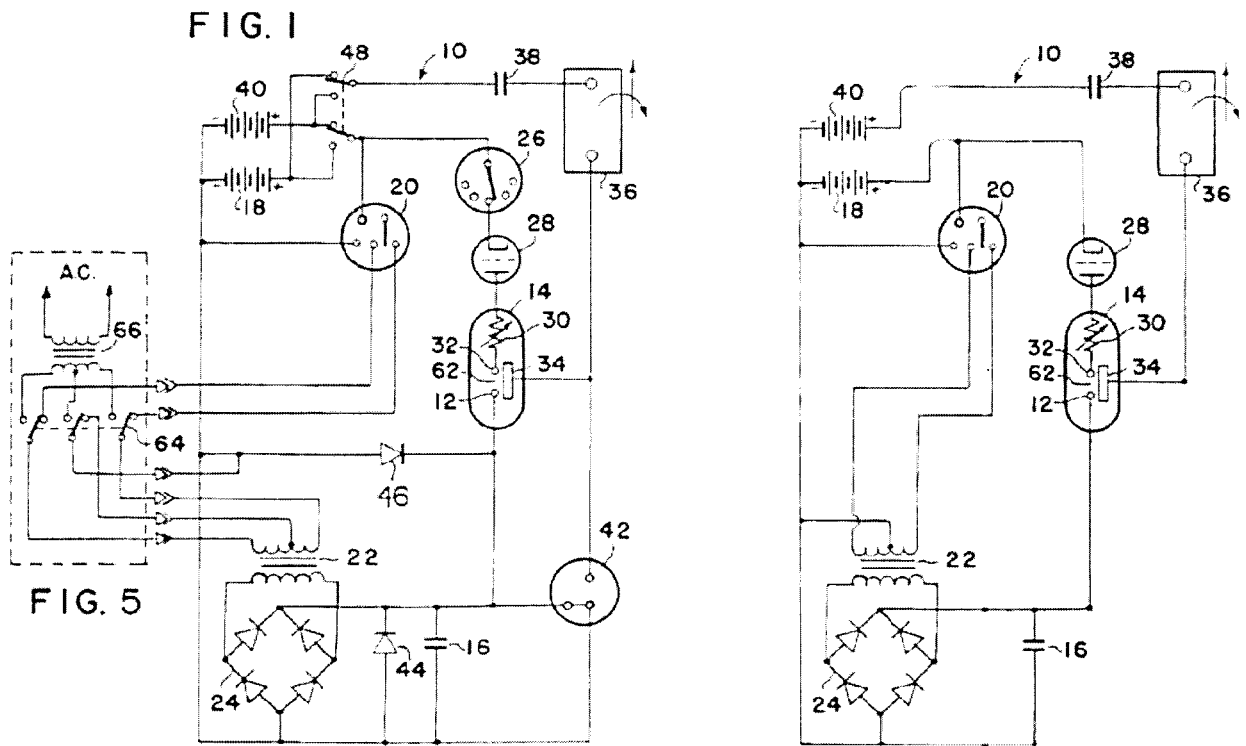

Figure 26 Gray's Circuit "Schematic" and the Simplified Gray's Circuit "Schematic"

## Chapter 4: Decoding Gray's Patents

In the previous chapters, I have taken a great deal of time to explain the intricacies of Tesla's Magnifying Transmitter because of how it directly relates to the operation of Ed Gray's cold electricity circuit. To better understand what his circuit is and how it operates, Figure 26 shows Gray's "schematic" on the left, as it is presented in Patent # 4,595,975, and on the right, it shows what I refer to as the "Simplified Gray Circuit `Schematic." (I'm using the term "schematic" in quotes because this is not entirely a schematic diagram.) In order to better understand this circuit in its most fundamental form, I would like to eliminate a number of components, temporarily, that serve functions outside of its essential operation, as follows:

- Components # 64 and #66 (shown within the dotted-line box) indicate an alternate way of running the circuit from an AC supply. These parts can be eliminated without changing the circuit in any significant way because the circuit can be run from the batteries.
- Components # 42, # 44, and # 46, which are the safety overshoot mechanisms referred to earlier, can be eliminated because we learned in Chapter 1, reading from the patent text, that these parts are included simply to protect the circuit in case it generates too much energy.
- Component # 26, which Gray calls a "commutator," is part of the timing mechanism. However, the vacuum

triode, # 28, is sufficient to give us the timing impulses for the discharge of our capacitor, so # 26 can be eliminated.

- Component # 48 is a switching mechanism that allows the operator to change which battery is powering the circuit and which battery the circuit is charging. This can be eliminated by simply indicating that battery 18 is running the circuit and battery 40 is receiving the charging impulses.

When all of these components are removed, we are left with the "Simplified Gray Circuit `Schematic" as shown on the right side of the diagram.

Figure 27 shows Tesla's Magnifying Transmitter Circuit next to Gray's Cold Electricity Circuit. I call this *The Common Features of Tesla's Magnifying Transmitter and Gray's Cold Electricity Circuit*. The important common features are as follows:

- They both start off with a source of high voltage direct current. In Tesla's case, it's a high voltage direct current generator, Source "B". In Gray's case, it starts with a battery, # 18, whose output is chopped through a multi-vibrator, #20. The impulses coming from the multi-vibrator power the low voltage, primary winding on transformer #22. The high voltage secondary winding of # 22 is then rectified with the full wave bridge, # 24. The output from # 24 is high voltage DC. But either way, both circuits begin with high voltage DC.
- The next component in both circuits is

the capacitor. In Tesla's circuit it is "C"; In Grays, it is # 16. Both circuits operate by having the capacitor charged repeatedly by the high voltage DC source.

- The next component in both circuits is the spark gap. In Tesla's circuit it is represented as "d-d". In Gray's diagram it is # 62. For each circuit to work properly, the spark in the gap must be characterized by two features: first, there must be a means to insure that the discharge will occur in only one direction, and second, there must be a means to control the duration of the spark. In the case of Tesla's circuit, we have the continuous pressure from the high voltage generator to insure the unidirectional discharge of the capacitor, and a magnetic field across the spark gap to blow-out the current as soon as it appears. The duration of the spark can be determined by both the strength of the magnetic field across the gap and by the size (capacitance) of the capacitor. In the case of Gray, we know that he was using very large capacitors, so he wasn't discharging the entire capacitor at one time. But his circuit was performing two functions: the resistor, # 30, limited the current in the discharge, and the vacuum tube, # 28, could not only shut off the discharge at whatever pulse duration he desired, but it also insured that no reversals of current appeared in this section of the circuit. So, again, all the necessary features are present.
- Next, both circuits have what I call the "Preferred Location for the ElectroRadiant Event." In Tesla's case, it is "two turns of stout wire," ("A") as he calls it, which is the primary of his electrical transformer. But as we know from reading Mr. Vassilatos, this is not a magnetically inductive transformer. The magnetic coupling is very weak between the primary and the secondary coils. In fact this device runs on what Tesla refers to as his new "electrostatic induction rules." In the case of Gray, the preferred location for the ElectroRadiant Event is what he calls his "conversion switching element tube," # 14. This component is clearly an electrostatic device, as we read earlier. It is specifically designed to have an explosive, electrostatic event radiate away from its central member.
- The next common element is the "Preferred Means to Intercept the Electro-Radiant Event." In Tesla's case, it's the secondary coil of his transformer, "F"; this is the conical or spiral shaped coil that Vassilatos mentions and that we've already seen in his patents. In Gray's case, it's the charge-receiving grids, # 34, that collect the radiant voltage. It's important to see that in both of these circuits, there is no direct connection between the source of energy and the "receiver element." Only the induced electroradiant charge appears on these output components.
- The next element is the "Connection to the Preferred Output." In Tesla's case, the output is the connection to the ground (E) and the elevated capacitance (E) that constitutes his World Broadcast System. In Gray' case, the output discharges from the "charge receiving grids" are directed to the inductive load, # 36. This element can represent either the jumping magnets or a transformer output that ran his cold electric circuit or the repulsive magnets in his motor. So again, each circuit has a preferred means to intercept the Electro-Radiant Event and a preferred method to connect it to the output.
- And finally, Gray was able to reconvert some of this excess energy back into ordinary electricity, and recycle enough



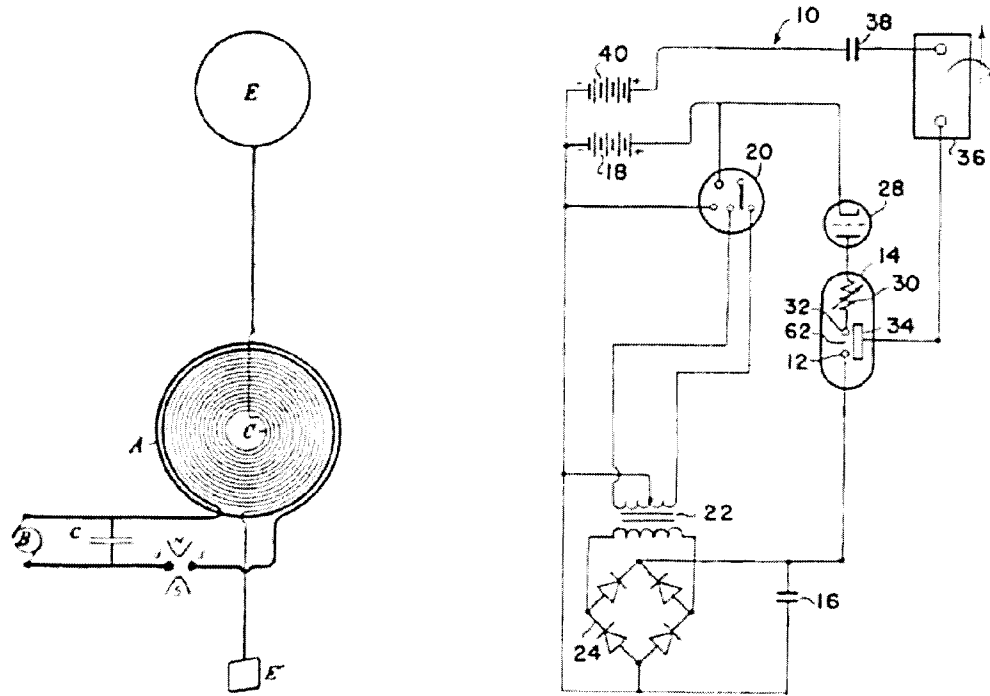

Common Features of Tesla's Magnifying Transmitter and Gray's Cold Electricity Circuit

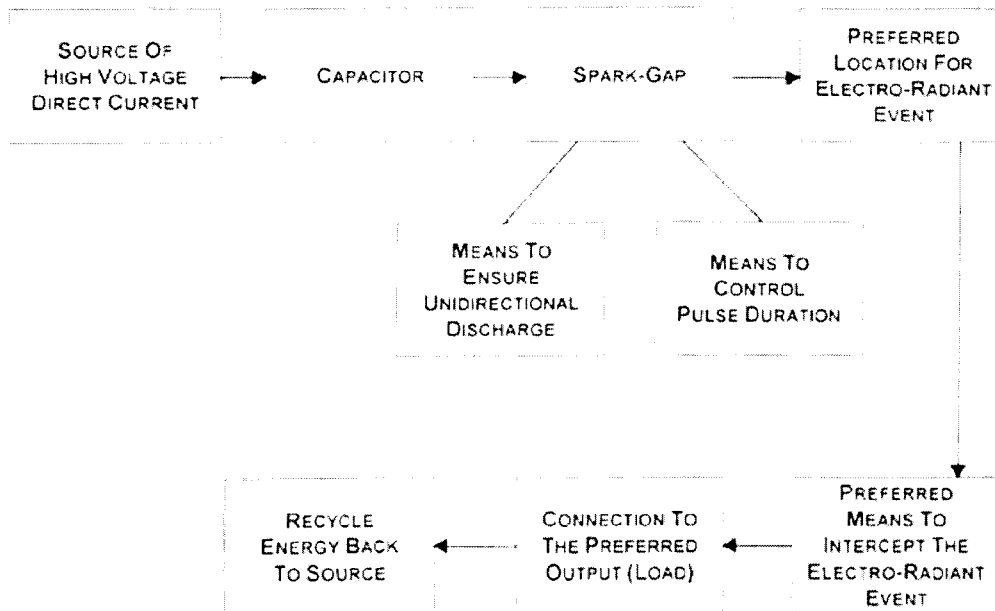
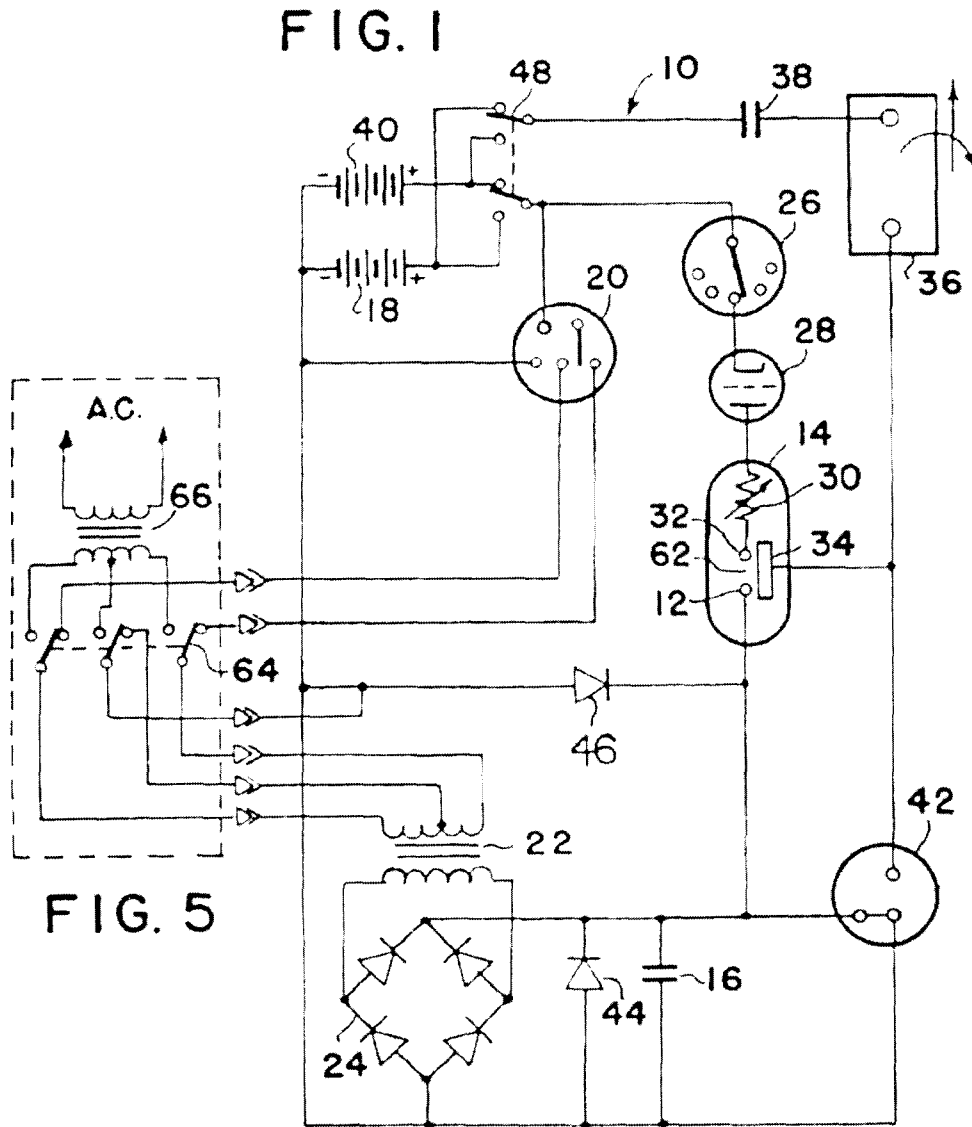

Figure 27  
Common Features of Tesla's Magnifying Transmitter and Gray's Cold Electricity Circuit



**Figure 28**  
Gray's Circuit "Schematic"

of it to actually recharge his battery, as we read earlier. Tesla was not concerned with this recycling process, since his system was designed to be powered by a hydroelectric power plant.

So it is clear from this analysis that Tesla's Magnifying Transmitter and Gray's Cold Electricity Circuits are, for all intents and purposes, the same circuit. They do the same things, in the same places, in slightly different ways, and they both claim to produce extremely high gains of a cold form of "electrostatic" energy in the output. Tesla's system was obviously much, much larger since he was planning to power up the whole world. Gray was only planning to power up your home or your car. But for all intents and purposes, these systems perform the same functions and release the same "Electro-Radiant" gain mechanism.

Once again, Figure 28 shows Gray's circuit "schematic" from his "Efficient Power Supply Suitable For Inductive Loads" patent. I realized, after studying this diagram for a long time, that there were a number of basic problems with the way it was drawn. First of all, let's look at component # 42. As this is drawn (remember that this is a spark overshoot device) there is a line connecting all the way through the bottom half. If this were supposed to be an actual electrical connection, it would produce a short circuit, and would not allow capacitor # 16 to charge up. So, it can clearly be seen that this part of the drawing has problems.

Next we will look at components # 26 and # 28 which are defined in the patent text as follows:

**Control of the conversion switching element tube is maintained by commutator 26. A series of contacts mounted radially about a shaft or a solid state switching device sensitive to time or other variable may be used for this control element. A switching element tube type one-way energy path, 28, is introduced between the**

**commutator device and the conversion switching element tube to prevent high energy arcing at the commutator current path.**

If the commutator, # 26, were a solid state device, there would be no "arcing" to prevent. Therefore, the stated purpose of # 28 in the patent text is misleading. However, component # 28 is described as a "one-way energy path." Gray is specifically saying that energy in this section of the circuit can only be allowed to move in one direction. This is the important condition to establish, because it is in strict compliance with the conditions Tesla set forth in order to create the "Electro-Radiant" event. There is also another glaring omission in connection to component # 28. The control grid in this triode device is not attached to anything, and that, of course, is what could control the timing of the spark discharge. In the patent text, there is no mention of how component # 28 functions and no mention of how the grid is controlled. Recognizing that component # 28 had no means of being controlled was an important realization for me.

The next problems I found were in the inductive load, component # 36. The first is that # 36 is described as an inductor but is not illustrated by a coil symbol as we see with components # 22 and # 66. Second, there are also two odd arrows associated with this component. The patent text implies that these may actually be two coils that repel each other to produce mechanical work. With this in mind, the arrows may represent the idea of two members deflected away from each other in some way. This is not made clear in the patent text. Third, we don't see any real current path through this component, so we don't know where the discharge goes. And finally, fourth, the circuit comes to the second capacitor, # 38. In the patent text this component is described as being a part of the recharging mechanism. However,

none of these component connections make any sense. For instance, if impulses coming from the inductor, # 36, start charging up capacitor # 38, there are no circuit connections shown that would allow it ever to be discharged. Therefore, because of these omissions, I came to view this section of the circuit more as a block diagram than as an actual schematic.

I came to the conclusion that all that is really apparent is that the charge receiving grids are in relationship to the inductive load, which is in relationship to the receiving capacitor, which is in some relationship to the recharging of the battery. Therefore, this section is a block diagram, merely indicating that these components are in relationship to each other, rather than showing exactly how they are wired together.

As we move towards a more complete understanding of what Gray's schematic diagram may actually look like, we will now turn our attention to his "conversion element switching tube" (Figure 29). This, finally, is the heart of the matter, the component that Gray always referred to as the "super secret means of generating and mixing static electricity." This is the element where the free energy is generated and collected.

The conversion element switching tube is really three components in one. It consists of the resistor # 30, the spark gap (the space between # 32 and # 12), and the area surrounded by the charge-receiving grids (# 34a & # 34b). Even though it is not stated in the patent text, we do know that the spark-gap is rated at about 3,000 volts, based on statements made by Gray in the newspaper articles quoted in Chapter 1. The rear extension of what Gray calls his "high voltage anode" (# 12) is the surface from which the Electro-Radiant event will be projected. This free energy blast will radiate away from # 12, perpendicular to the flow of current in the path of the spark

discharge moving down that surface. The material composition of # 12 is represented as being relatively thick. It is not just a wire. But what are its characteristics? The patent doesn't describe them. We might hypothesize that this material is a bare metal with no insulation on it. It could possibly have a mirror finish, made of stainless steel or a non-magnetic material. A wide variety of options need to be tested here, but very possibly the element's diameter could be an important factor, as well as whether or not it is solid or hollow. These questions need to be explored and remain among the only unknowns.

The concentric receiving grids (# 34a & # 34b) around # 12 are designed to intercept the electro-radiant event. As indicated before, the patent states, "This element utilizes a low voltage anode, a high voltage anode, and one or more electrostatic or charge-receiving grids." This drawing clearly shows two charge-receiving grids. In the section from Gray's patent, which refers to this component, he says:

**The shape and spacing of the electrostatic grids is also susceptible to variations of application, voltage, current, and energy requirements. It is the contention of the inventor that by judicious mating of the elements of the conversion switching element tube and the proper selection of the components of the circuit elements of the system, the desired theoretical results may be achieved. It is the inventor's contention that this mating and selection process is well within the capabilities of intensive research and development technique.**

I'm sure this was his very nice way of saying, "This is all I'm going to tell you, but you can probably figure it out if you know what you're doing." Then he says:

**The preferred embodiment of this invention merely assumes optimum utilization and optimum benefit from this invention when used with portable energy devices similar in principle to the wet cell or dry cell battery. This invention proposes to**

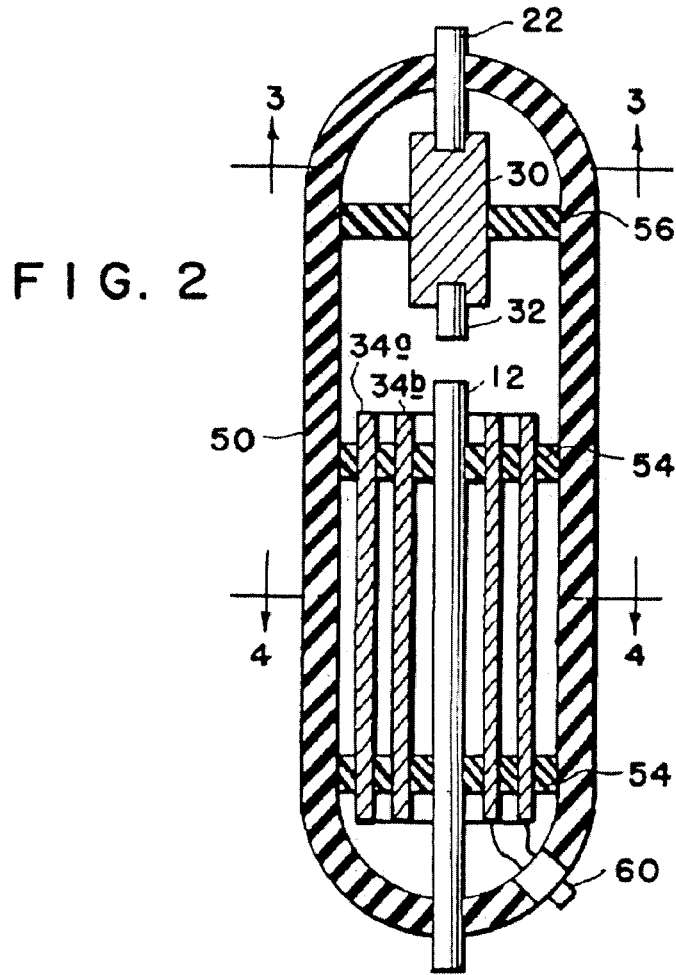

**FIG. 3**

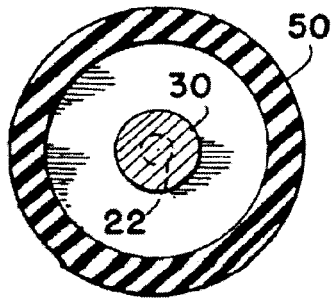

**FIG. 4**

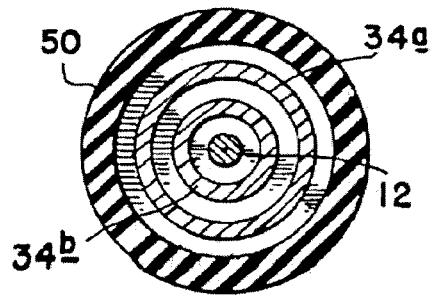
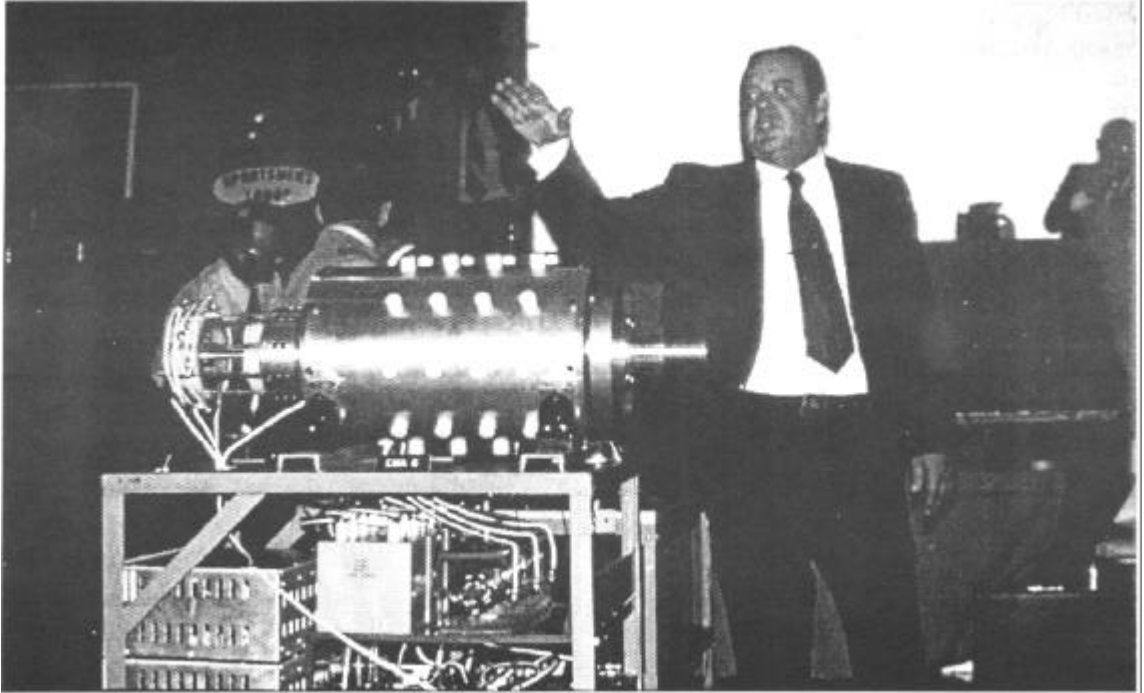

Figure 29  
Grays Conversion Tube Diagram



**Figure 30**

Edwin Gray and His # 6 Motor Prototype

**utilize the energy contained in an internally-generated, high-voltage electric spike to electrically energize an inductive load, this inductive load being then capable of converting the energy so supplied into a useful electrical or mechanical output.**

Here we have clear statements by Gray that the conversion element switching tube is the source of the useful outputs. In fact, this component is what powered his magnet popping experiment; this is what ran his circuit, that ran the TV, radios, and light bulbs, and this is the component that ran his motor. This is the element where the energy is both magnified and characterized as "cold electricity." Henceforth, I will refer to this structure as an "Electro-Radiant Transceiver", because it is designed to both broadcast and receive the "Electro-Radiant Event."

Having established these points, there are still a number of unknowns which need to be explored. For instance, there appears to be no provision, in these drawings or in the patent text, to determine whether or not

there's a vacuum in this enclosure, or if it is filled with air or some other gas. The quotes from Gray in the *NewsReal* article reveal that he learned how to harness this effect by studying lightning. The article also states that he noticed lightning was stronger nearer the ground and that he assumed it had something to do with "more air." So, it is possible that the inside of the tube is not a vacuum environment. Although we know that the output "cold electricity" won't shock you, the capacitor discharge could, so the case around the component, # 50, might still be for safety reasons. Two safe assumptions are: 1) # 50 can be considered a mechanical means of holding the components together, and 2) that there is probably air in this enclosure.

We also don't know the physical size of this device, and we don't know the physical dimensions of the charge receiving grids, including their length or diameter. That is, until we examine the photographic evidence of Tom Valentine.

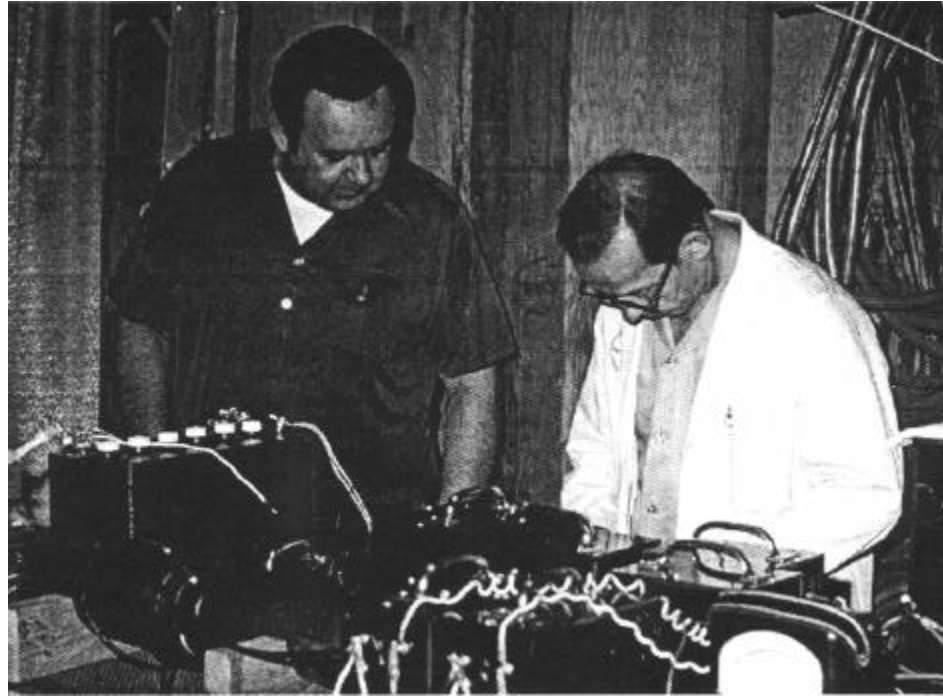

**Figure 31**

Edwin Gray and Fritz Lens in 1973

In Figure 30 (and the color photograph shown on the back cover of the book), Ed Gray is standing before a meeting of his stockholders. In the enlargement of the inset image on the back cover, the “magic component” can clearly be seen. A lot of information is revealed in this photograph about the layout of the device; in particular, the physical dimensions of the conversion element switching tubes, that I am now calling the Electro-Radiant Transceivers. There is a row of three conversion tubes and each one is being fed by the discharge of a single capacitor. Three very large capacitors can easily be seen. I had this image digitally scanned, and when I looked at the markings on this capacitor in extreme magnification, it read “2 micro-farads” and “4000 Volts DC.”

So, where Gray's motor patent shows a bank of eighteen capacitors being charged and discharged in sequence to run the motor, that's not what he was really doing. The evidence from the circuit patent and this photograph clearly shows that the

motor coils were being powered from the output of the conversion tubes, and not directly from the capacitor discharges. The photograph shows only one wire coming out of each of the three conversion tubes going up to the commutator, with just a single wire return. So, it is most likely that Gray is discharging the charge receiving grids to ground through his magnet coils. The inset enlargement clearly shows two charge receiving grids in the tube, about 1/4 of an inch away from each other.

Exactly how they are connected is still not certain. The patent suggests that each grid is wired out to the plug, # 60, and that there is one connection from there to the output Inductor.

Figure 31 shows another unpublished photograph taken by Tom Valentine in Ed Gray's laboratory in 1973, showing Ed Gray and Fritz Lens at their laboratory bench. The arrangement of parts shown in the foreground is the setup used to demonstrate the "popping magnets." In the lower left portion of the photograph is what appears

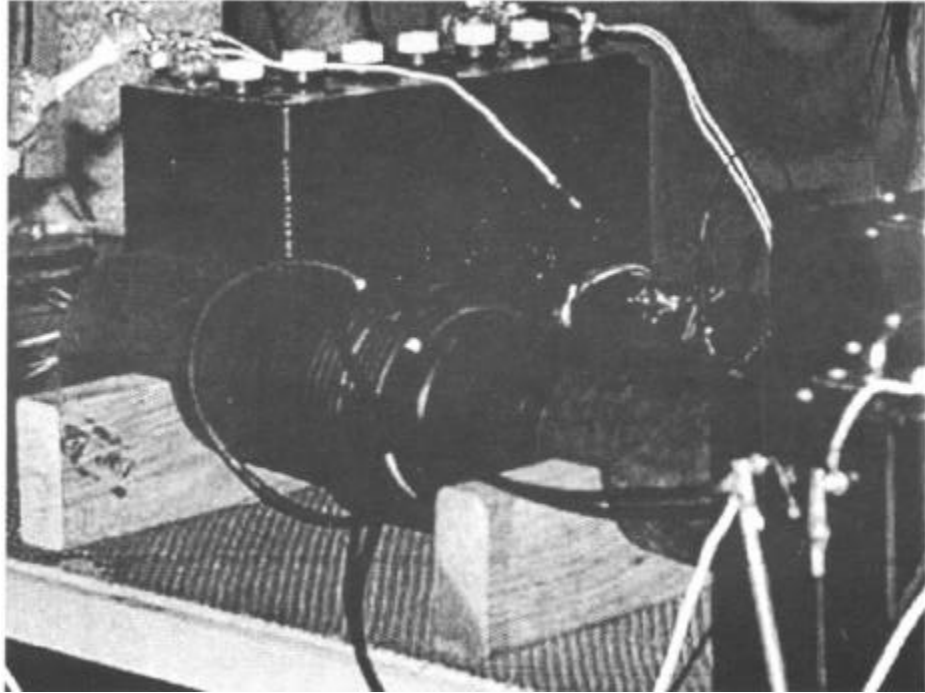

**Figure 32**  
Gray's Inductive Load

to be an air core transformer wound on a 4-inch diameter piece of PVC, resting on some wooden blocks (Figure 32). This circuit element is probably taking the discharge from the conversion element switching tube and inductively coupling it to a secondary winding. It is the secondary winding that powers the magnets, which are wired in series, making them fly away from each other. In order to create repulsive impulses that are timed perfectly to each other, Gray has this air core transformer powering the magnets simultaneously. He is using an air core transformer here in the first stage, because the impulse frequency is so high. A digitally-enhanced close-up image of this component shows the central winding as two layers of ten turns each of what looks like spark plug wire.

This, then, is Gray's "inductive load." This is how he is harnessing the energy from the charge receiving grids of the conversion element switching tube, enabling him to do real work.

But possibly the best piece of evidence that supports this concept of the output, is that found in Tesla's US Patent # 685,958 titled "Method of Utilizing Radiant Energy." Figure 33 shows one of the illustrations from this patent. Here we see plate "P" being exposed to some source of Radiant Energy and then being discharged to ground through the primary winding of a transformer. So all of the evidence supports this idea of the output.

At this point, we have enough evidence to theorize on what Edwin Gray's cold electricity circuit schematic may actually be. Figure 34 is a diagram I created called "Probable Schematic for Edwin Gray's Cold Electricity Circuit." The front end is identical to Gray's drawing, complete with the battery, # 40, multi-vibrator, # 20, step-up transformer, # 22, full-wave bridge, # 24, capacitor, # 16, and the protective mechanisms, # 42, # 44, and # 46. Next, just like Gray's again, is the Electro-Radiant Transceiver mechanism, # 34, showing the spark gap, # 62, resistor, # 30, vacuum



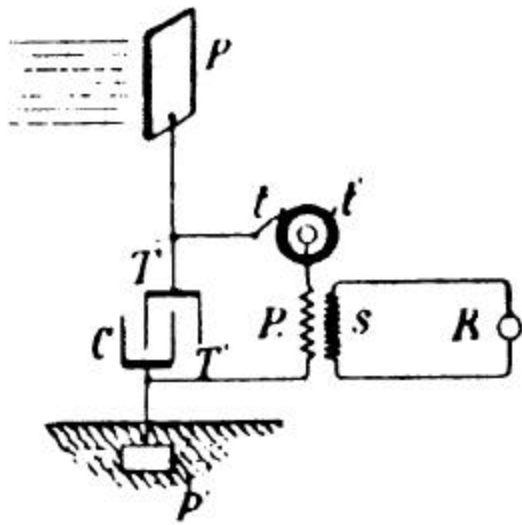

**Figure 33**  
Tesla's Radiant Energy Method

grid of the triode is a timer control circuit capable of generating pulse trains as needed, with pulse durations in the 10 to 50-microsecond range.

In the output section, I show the two grids of the Electro-Radiant Transceiver, # 34, wired to each other. They, in turn are connected to the primary of the air core transformer, which is connected to the ground. The secondary of the air core transformer is a voltage step-down to power lights and other medium voltage appliances. This section of the circuit is also connected to another step-down transformer whose secondary would be rectified to charge another capacitor, # 38. As current pulses accumulate, this capacitor, # 38, will charge to a voltage that is higher than battery # 18, and therefore will begin to charge this secondary battery.

The spark overshoot mechanism, # 42, is shown as two separate high voltage spark gaps, one on the primary line used to dump any Electro-Radiant discharge that backs up

in the primary circuit, and the other used to dump any excess voltage in the output circuit.

Referring to the vacuum tube # 28, we know first of all, according to Vassilatos, that in order to create the non-shocking form of electricity, Tesla said the spark duration must be limited to anything less than 100 microseconds. We also know from Dr. Chalfin's statement in the *NewsReal* article, that Gray used power for "only a small fraction of a millisecond." The pulse timing I have suggested, at between 10 and 50 microseconds, represents between 1% and 5% of a millisecond. This certainly represents "a small fraction." Secondly, the vacuum tube # 28 also acts like a super-fast diode to prevent any reversals in current.

As stated before, capacitor # 16 discharges through the Electro-Radiant Transceiver back to the positive of the battery. Normally, if a capacitor is discharged, the high voltage positive would be discharged back to the negative terminal. However, it is indicated that Gray discharged his capacitor back to the positive of the battery. Tesla clearly showed that this is not necessary to create the ElectroRadiant Event, but Gray must have felt it was important. The significance of this is not yet known, but it certainly must be related to his idea of "splitting the positive," a piece of jargon used in early reports about his technology. Clearly, it had nothing to do with "recharging" battery # 40. The voltage drop at the spark gap reduces the amount of energy that can be returned to this battery to near zero. So this cannot be the recharging mechanism. In all probability, by connecting back to the positive of the battery, Gray is characterizing the ElectroRadiant Event in a more "positive" way. When I say "positive", I mean electropositive. So, now we have some notion of where Gray's terminology, "splitting the positive" comes from, and what its

Probable Schematic for Edwin Gray's Cold Electricity Circuit

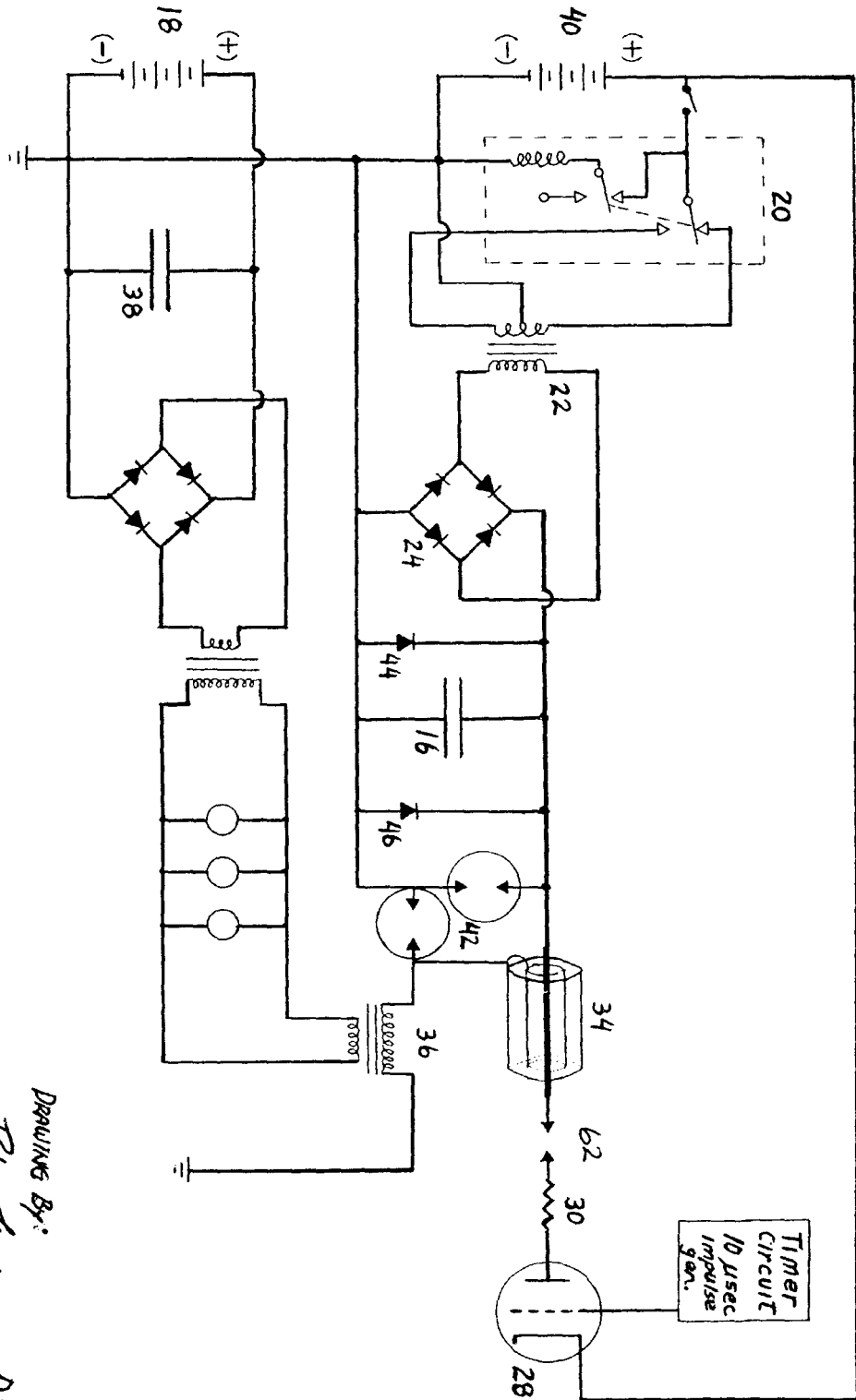

Drawing By:  
 Peter Fiedemann D.Sc.  
 August, 2000

Figure 34  
 Probable Schematic for Gray's Cold Electricity Circuit

significance might be. Also, Gray claims that he uses only a positive form of energy. Certainly what gets radiated out onto his charge receiving grids is a positive, electrostatic charge. When that impulse is discharged to ground, he is only using the positive side of electricity. Therefore, everything Gray said makes sense.

The photographic evidence in the image on the back cover strongly suggests that the charge receiving grids in Gray's conversion tubes are copper. As we have said before, Electro-Radiant effects create "electronic" responses in certain metals. Gray must have figured out that he could create an electronic charge on his receiving grids if he intercepted the Electro-Radiant Event on copper. In Tesla's large radiant energy system, he learned to avoid using copper to prevent the electronic contamination it created. But in Gray's smaller system, this was just what he needed. The more the Electro-Radiant energy interacts with copper again, the sooner it returns to a form of electricity that will actually charge the battery in a fairly normal way. This then is how Edwin Gray produced cold electricity.

To summarize, Gray's cold electricity circuit runs like this: It starts with power out of the battery; he raises it to 3000 volts DC that he stores in a very large capacitor. He then discharges impulses through a spark gap, clipped by a vacuum tube, such that the impulse duration is less than 50 microseconds. This staccato of impulses flows through the Electro-Radiant Transceiver, which creates a series of radiant, electrostatic fields of spatially distributed voltage that is picked up by the charge-receiving grids. As soon as the Electro-Radiant Event ceases, these charged grids discharge to ground through the primary of the "inductive load." The output recovery system is inductively coupled to this discharge primary with a voltage step-down to run light bulbs and other medium voltage appliances, as well as another step-

down transformer to recharge the secondary battery. By switching the batteries back and forth periodically, Gray could keep the system going indefinitely, and still produce a sizable output.

At this point, there is only one final error to point out. In the patent text, Gray proposes a theory as to where the excess energy is coming from. He suggests that the gain in energy that appears on the receiving grids is the "equivalent" of the current from the low voltage anode (battery # 40) times the voltage from the high voltage anode (Capacitor # 16), combining in the spark discharge. He states: "Because the duration of the arc is very short, the instantaneous voltage, and instantaneous current may both be very high. The instantaneous peak apparent power is therefore, also very high." This is clearly not true. I have tried dozens of methods to combine the voltage from one source with the current from another source in an attempt to create a power cross-product. It doesn't work. But the best evidence that Gray was not doing this he in these two points. First, such a scheme, if it were possible, would produce normal, HOT electricity. And second, Gray's conversion tube has a resistor between the spark-gap and the battery source, clearly blocking the availability of unlimited current. So, Gray's explanation of the "gain mechanism" cannot be true. He either put this in the patent because he didn't really understand the effect himself, or because he thought this explanation would get past the Patent examiners more easily. (I personally believe Gray understood how to create the effect, but he didn't know how to explain it.)

Gray's statement that he only used 1% of the energy and that 99% went back into the battery is actually a meaningless attempt to explain this phenomenon in Thermodynamic terms. Actually, all of the energy in his primary circuit is lost. The capacitor # 16 discharges into the spark-gap,

where 99% of the work potential of the energy is lost in the voltage drop, not to mention the fact that there is no output “work device” in the discharge path to take advantage of the impulse. So, 100% of the input energy is lost in terms of ordinary work conversion. It does do something else though. It produces a series of unidirectional discharges that release a series of “Electro-Radiant” events that are discharged through the real output “work device.” This work output is 100 times greater than the energy lost to create it.

If, at this point, there is still skepticism regarding the properties of Gray's circuit, the following may help to put all of this in perspective. Figure 35 shows a classic image of the enigmatic Testatika Machine, designed by Paul Baumann at the Methernitha Community in Linden, Switzerland. Mr. Baumann claims he learned how to build this device by studying lightning. It has a Wimshurst Machine as the high voltage, electro-static front end, which charges two capacitors or Leyden Jars. The high voltage from those capacitors goes down into the tops of the large cans, (the insides of which Mr. Baumann has never let anyone see) then, comes out the bottoms and meets in a spark gap. There has been endless speculation regarding the construction of these “big cans,” ranging from Uraniumdoped capacitors to strange arrangements of crystals and magnets. But, I submit to you that these “big cans” are Electro-Radiant Transceivers, and that they are not altogether different from Gray's Conversion Tube design.

It is interesting to note that Mr. Baumann has placed one can on either side of the spark-gap, the first, probably producing a positive Electro-Radiant Event, and the second, producing a negative Electro-Radiant Event. You may recall that Vassilatos reported that Tesla said, depending on the location of the spark-gap,

he could either project a charge or deplete a charge from a surface. So this is what a fully balanced system might look like, where the output pulses actually resolve the charge from an Electro-Radiant positive surface to an Electro-Radiant negative surface, instead of just from one grid to ground, like in Gray's system.

Figure 36 clearly shows that this little Wimshurst Machine has no trouble at all creating big lighting effects. The claim in this image is 1,000 watts of light. The gain here must be close to 1000 to 1, not to mention the fact that the machine is turning itself.

All the evidence supports the conclusion that Edwin Gray's “Cold Electricity” circuit runs on Radiant Energy, and is a “close cousin” of devices developed by Dr. Nikola Tesla and Dr. Thomas Henry Moray. This also places it within a larger group of technologies that effectively tap the Ether for usable work. It is the only explanation that fits all of the evidence.

In order to understand these Etheric technologies better, the researcher must study only those teachings that contribute to these vitalistic traditions. The model of the Ether that I have found to be the most accurate and useful, is that set of ideas put forward by Dr. Rudolf Steiner. (The best source book to study Steiner's Ether model is *Etheric Formative Forces in Cosmos, Earth and Man* by Dr. Guenther Wachsmuth.) In this model, there are four primary octaves of the Ether. These are the Light Ether, the Warmth Ether, the Chemical Ether, and the integrated synthesis of these first three, called the Life Ether. Steiner describes electricity as “an unnatural combination of Warmth Ether and Light Ether.” The term “unnatural” used here simply means, not found in nature. While these terms are slightly different, you may be able to see the parallels between this idea and the conclusions that Tesla was arriving at. The Light Ether is related to voltage, capacitance

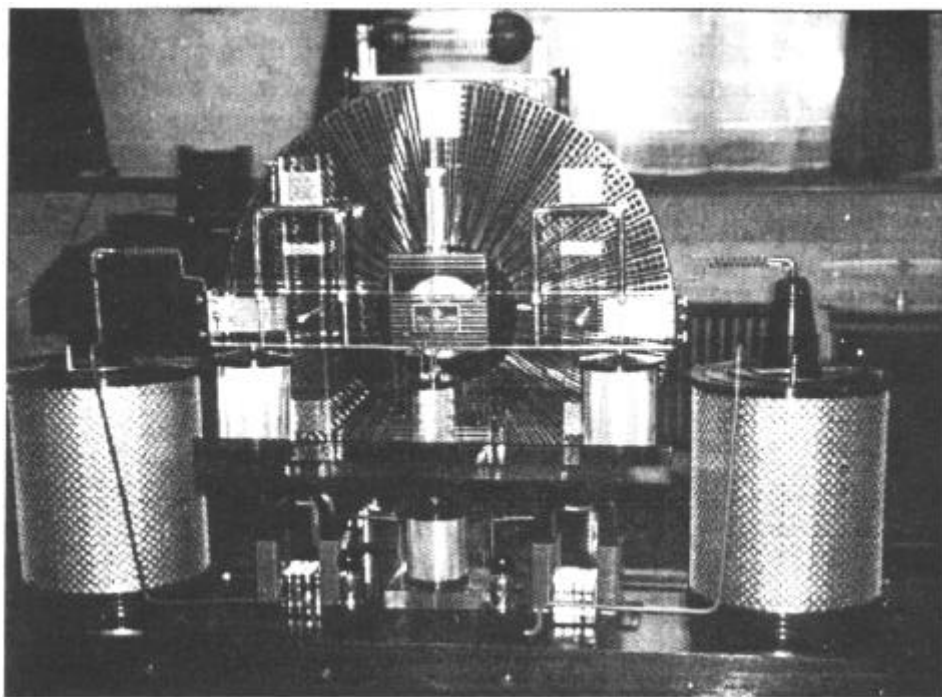

**Figure 35**  
Paul Baumann's Testatika Machine

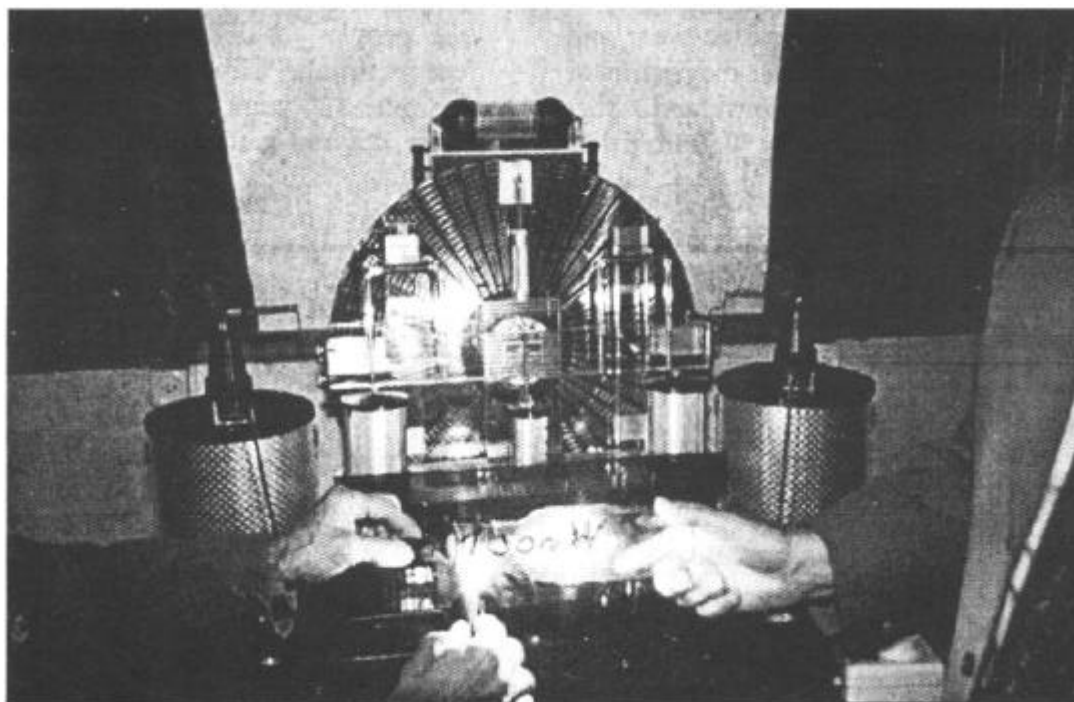

**Figure 36**  
Testatika Machine Lighting a Light Bulb

and the dielectric forces in nature, where as the Warmth Ether is related to current, resistance, and the magnetic forces in nature. Longitudinal rays of Light Ether propagate instantaneously to any distance, even to inter-stellar and inter-galactic distances. This medium is cool, and not wholly responsive to what is generally referred to as electrical resistance. This means that even Ohm's Law is useless for accurately determining circuit behaviors when this medium is present.

More importantly, however, this relates to the great quest for the so-called "room temperature super-conductor." It's possible that looking for the lowest resistance conductor may be the wrong goal. A purified stream of Light Ether is the true "room temperature super-conductee." This medium is best "conducted" by pure carbon, according to Tesla, but it can also be "reflected" down a wide variety of mirror finish, silver metals, and transparent plastic polymers.

Electricity is not a monolithic event, and it is definitely not simply the movement of electrons. Tesla demonstrated that electricity can be split into its Warmth Ether

and Light Ether fractions. When this happens, the Light Ether speeds off at right angles, leaving the Warmth Ether behind, and entrains a huge volume of energy from the environment. It is imperative for modern day researchers to understand that the Laws of Thermodynamics and Maxwell's equations do not pertain to Etheric technologies, and therefore do not define the total set of possible realities that can be investigated in electrical science.

Besides Tesla, Gray, and Baumann, there are many other inventors who also discovered how to tap the Ether and make it do useful work. Among these are: John W. Keely in 1872, Nathan B. Stubblefield in 1880, Thomas Henry Moray in 1926, Viktor Schauburger in the 1920's, Dr. Wilhelm Reich in 1940, and dozens of others in the last 50 years. Most notably are Trevor Constable, and Dr. Robert Adams, of New Zealand.

In light of this, there is ample evidence to suggest that God has been trying to give the peoples of this world low cost, clean energy, in the form of Etheric technology for over 120 years. It is time to spiritually wake up, and graciously accept the Divine gift.

## APPENDICES I, II, III





## **APPENDIX I**

### *Three U.S. Patents by Edwin V. Gray*

1. USP # 3,890,548 - "Pulsed Capacitor Discharge Electric Engine"
2. USP # 4,595,977 - "Efficient Power Supply Suitable for Inductive Loads"
3. USP # 4,661,747 - "Efficient Electrical Conversion Switching Tube Suitable for Inductive Loads"

- [54] **PULSED CAPACITOR DISCHARGE  
 ELECTRIC ENGINE**
- [75] Inventor: Edwin V. Gray, Northridge, Calif.
- [73] Assignee: Evgray Enterprises, Inc., Van Nuys, Calif.
- [22] Filed: Nov. 2, 1973
- [21] Appl. No.: 412,415
- [52] U.S. Cl. .... 318/139; 318/254; 318/439;  
 310/46
- [51] Int. Cl. .... H02p 5/00
- [58] Field of Search ..... 310/46, 5, 6; 318/194,  
 318/439, 254, 139; 320/1; 307/110

- [56] **References Cited**
- UNITED STATES PATENTS**
- |           |         |         |         |
|-----------|---------|---------|---------|
| 2,085,708 | 6/1937  | Spencer | 318/194 |
| 2,800,619 | 7/1957  | Brunt   | 318/194 |
| 3,579,074 | 5/1971  | Roberts | 320/1   |
| 3,619,638 | 11/1971 | Phinney | 307/110 |

**OTHER PUBLICATIONS**

Frungel, *High Speed Pulse Technology*, Academic Press Inc., 1965, pp. 140-148.

Primary Examiner—Robert K. Schaefer  
 Assistant Examiner—John J. Feldhaus  
 Attorney, Agent, or Firm—Gerald L. Price

[57] **ABSTRACT**

There is disclosed herein an electric machine or engine in which a rotor cage having an array of electromagnets is rotatable in an array of electromagnets, or fixed electromagnets are juxtaposed against movable ones. The coils of the electromagnets are connected in the discharge path of capacitors charged to relatively high voltage and discharged through the electromagnetic coils when selected rotor and stator elements are in alignment, or when the fixed electromagnets and movable electromagnets are juxtaposed. The discharge occurs across spark gaps disclosed in alignment with respect to the desired juxtaposition of the selected movable and stationary electromagnets. The capacitor discharges occur simultaneously through juxtaposed stationary movable electromagnets wound so that their respective cores are in magnetic repulsion polarity, thus resulting in the forced motion of movable electromagnetic elements away from the juxtaposed stationary electromagnetic elements at the discharge, thereby achieving motion. In an engine, the discharges occur successively across selected ones of the gaps to maintain continuous rotation. Capacitors are recharged between successive alignment positions of particular rotor and stator electromagnets of the engine.

18 Claims, 19 Drawing Figures

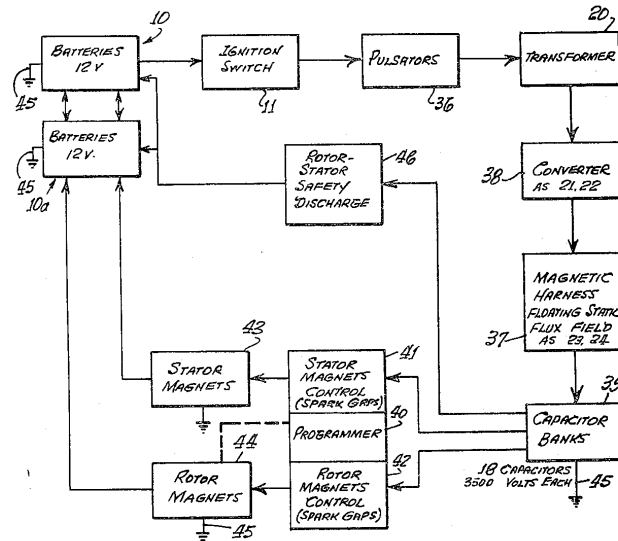

## PULSED CAPACITOR DISCHARGE ELECTRIC ENGINE

### BACKGROUND OF THE INVENTION

#### 1. Field of the Invention

There is no known engine or motor operated on the principle of the present invention, that a capacitor charged to a relatively high voltage from a low-voltage d-c source is discharged across a spark gap to provide current through motor drive coils in the discharge path, these being solenoids which generate motion by magnetic repulsion of juxtaposed pairs of cores. The solenoids are preferably configured in motor and stator assemblies to effect motion of the rotor element with respect to the stator.

The present invention utilizes this principle to provide a rotary motion machine or engine which can develop considerable torque through the magnetic repulsion action of rotor and stator cores wound with coils through which capacitors are discharged synchronously with the positioning of the rotor coils opposite particular stator coils. Similarly, a linear action can be achieved with a stationary electromagnet juxtaposed against a movable electromagnet and the movable electromagnet can perform work with a tool or piston attached thereto.

A novel control mechanism is associated with the rotor is the engine to position discharge elements appropriately to create the desired discharge through the electromagnet coils when the juxtaposed rotor and stator electromagnets are in alignment. The electromagnets in the stator and rotor are so arranged that the control mechanism can advance or retard the discharge points relative to rotor-stator positions for control of rotational speed.

The discharge overshoot or back e.m.f. from the collapsing fields in the coils from the capacitor discharge is used to energize external batteries for conservation of power. The recovered energy thus stored may be used to operate equipment associated with the engine or motive force producing device.

The engine or rotary electric machine of the invention is believed to operate on the principle of conservation of energy, in that once rotation is achieved, current is needed only at the instant of a capacitor discharge in order to advance the rotor. The rotor moves to the next discharge point on the inertia of the repulsion action. The capacitor is recharged during the interval and stores the energy until discharge at the next rotor-stator coil coincidence. Thus, the new engine produces torque and stores the excess energy for subsequent use.

In a linear motion device according to the invention, only a single pulse discharge is needed to perform work.

The applications of the engine include use as an electric automotive engine which is economical and which can regenerate a part of the energy consumed to provide power for other loads in the automotive electric vehicle. As a linear actuator an economical use of power is possible because each stroke will result from a single discharge pulse of a capacitor through a coil.

#### 2. Prior Art

Heretofore, electric engines or motors have operated on the principle that a conductor carrying a current in a magnetic field tends to move perpendicularly to that field; the electromagnetic torque developed by an ar-

mature or rotating portion of the motor is proportional to the magnetic flux in the stationary field and to the armature current.

In direct current motors the field is created by current through two or more field coils disposed in opposing magnetic relationship in the motor casing, while current through a rotatable armature positioned in the field is alternately reversed in polarity to provide continuous motion. The polarity reversing mechanism is a commutator. Some d-c motors have their field windings electrically in parallel with the rotor armature winding and are called "shunt-wound" motors. Other d-c motors have field and armature windings connected in series. In both series and shunt motors commutators are used for reversing the magnetic polarity of the armature to maintain rotation within the field.

A third type of d-c motor utilizes a permanent magnet field so that the operating current passes only through the armature winding. Such motors also use polarity reversing commutators to maintain direction of rotation. Reversal of direction of motion is effected by reversing the polarity of applied d-c potential.

Control of speed of d-c motors is accomplished basically by decrease or increase of magnetic field flux or the current through the armature. Either or both of these effects can be accomplished by raising or lowering the applied potential. In shunt motors, a series resistance may be varied to produce speed changes. In a permanent magnet motor or series motor, speed variation is best accomplished by voltage variation with a variable resistance in series with the motor d-c supply.

In alternating current motors, as is well known, a rotating magnetic field is created in the stator, and the rotor may be wound with as many poles as there are in the stator, with terminals connected with slip rings, or the rotor may consist of solid bars shorted by rings on each end to form a "squirrel cage" configuration. The speed of an a-c motor depends on the frequency of the applied a-c energy, if the motor is synchronous.

"Universal" motors are operable on either a-c or d-c energy.

In stepping motors, a rotor is moved from one pole to the next adjacent pole with each application of current, the rotor remaining at that position until a next application of current. This is accomplished by switching the current on and off or by pulsing the current. Examples of stepping motors are described in U.S. Pat. No. 3,467,902 to Shimizu, et al., U.S. Pat. No. 3,462,667 to Jackson, and U.S. Pat. No. 3,599,069 to Welch.

Operation of the a-c and d-c motors described above involves the consumption of substantial electric current. These motors can generate electric current when driven externally by a mechanical force. External energy to rotate the generator rotors can be provided by hydroelectric and steam sources or by other electric motors. In some of these systems, a d-c motor source drives an a-c generator for conversion of d-c energy to a-c energy or a d-c motor may drive a d-c generator which delivers a higher voltage than the source.

An extensive prior art search by the applicant uncovered no capacitor-discharge-operated motor resembling that of the present invention. All motors of the patents located in the search employed direct electrical connection between coils and electric power sources. Where selective switching is involved, semiconductor devices are employed, such as silicon-controlled rectifi-

ers. Capacitors are used only for starting and phasing purposes, and not for basic motor operation from the discharge thereof, as in this invention.

#### SUMMARY OF THE INVENTION

This invention relates to electric motors or engines, and more particularly to a new electric machine including electromagnetic poles in a stator configuration and electromagnet poles in a rotor configuration wherein in one form thereof the rotor is rotatable within the stator configuration and where both are energized by capacitor discharges through rotor and stator electromagnets at the instant of the alignment of a rotor electromagnet with a stator electromagnet. The rotor electromagnet is repelled from the stator electromagnet by the discharge of the capacitor through the coils of both the stator and rotor electromagnets at the same instant.

In an exemplary rotary engine according to this invention, rotor electromagnets may be disposed 120° apart on a central shaft and major stator electromagnets may be disposed 40° apart in the motor housing about the stator periphery. Other combinations of rotor elements and stator elements may be utilized to increase torque or rotation rate.

In another form, a second electromagnet is positioned to one side of each of the major stator electromagnets on a center line 13½° from the center line of the stator magnet, and these are excited in a predetermined pattern or sequence. Similarly to one side of each major rotor electromagnet is a second electromagnet spaced on a 13½° center line from the major rotor electromagnet. Electromagnets in both the rotor and stator assemblies are identical, the individual electromagnets of each being aligned axially and the coils of each being wired so that each rotor electromagnetic pole will have the same magnetic polarity as the electromagnet in the stator with which it is aligned and which it is confronting at the time of discharge of the capacitor.

Charging of the discharge capacitor or capacitors is accomplished by an electrical switching circuit wherein electrical energy from a battery or other source of d-c potential may be applied in alternating polarity to ignition coils or other voltage step-up arrangements from which a high voltage d-c potential is derived through rectification by diodes.

The capacitor charging circuit comprises a pair of high frequency switchers which feed respective automotive-type ignition coils employed as step-up transformers. The "secondary" of each of the ignition coils provides a high voltage square wave to a half-wave rectifier to generate a high voltage output pulse of d-c energy with each switching alternation of the high frequency switcher. Only one polarity is used so that a unidirectional pulse is applied to the capacitor bank being charged.

Successive unidirectional pulses are accumulated on the capacitor or capacitor bank until discharged. Discharge of the bank of capacitors occurs across a spark gap by arc-over. The gap spacing determines the voltage at which discharge or arc-over occurs. An array of gaps is created by fixed elements in the engine housing and moving elements positioned on the rotor shaft. At the instant when the moving gap elements are positioned opposite fixed elements during the rotor rotation, a discharge occurs through the coils of the aligned rotor and stator electromagnets to produce the repul-

sion action between the stator and rotor electromagnet cores.

A plurality of fixed gap elements are arrayed in the motor housing to correspond to the locations of the stator electromagnets in the housing. The rotor gap elements correspond to the positions of the rotor electromagnets on the rotor so that at the instant of correct alignment of the gaps the capacitors are discharged to produce the necessary current through the stator and rotor coils to cause the electromagnets to repel one another.

The charging circuits are arranged in pairs, and are such that the discharge occurs through both rotor and stator windings of the electromagnets, which are opposite one another when the spark gap elements are aligned and arc-over.

The speed of the rotor can be changed by means of a clutch mechanism associated with the rotor. The clutch shifts the positions of the rotor gap elements so that the discharge will energize the stator coils in a manner to advance or retard the time of discharge with respect to the normal rotor/stator alignment positions. The discharge through the rotor and stator then occurs when the rotor has passed the stator 6% for speed advance.

By causing the discharge to occur when the rotor position is approaching the stator, the repulsion pulse occurs 6% before the alignment position of the rotor and stator electromagnets, thus slowing the speed.

The clutch mechanism for aligning capacitor discharge gaps for discharge is described as a control head. It may be likened to a firing control mechanism in an automotive combustion engine in that it "fires" the electromagnets and provides a return of any discharge overshoot potential back to the battery or other energy source.

The action of the control head is extremely fast. From the foregoing description, it can be anticipated that an increase in the speed or a decrease in speed of rotation can occur within the period in which the rotor electromagnet moves between any pair of adjacently located electromagnets in the stator assembly, which are 40° apart in the exemplary engine according to the invention. Thus, speed changes can be effected in a maximum of one-ninth of a revolution.

The rotor speed-changing action of the control head and its structure are believed to be further novel features of the invention, in that they maintain normal 120° firing positions during uniform speed or rotation conditions, but shift to ±6% longer or shorter intervals for speed change by the novel shift mechanism in the rotor clutch assembly.

Accordingly, the preferred embodiment of this invention is an electric rotary engine wherein motor torque is developed by discharge of high potential from a bank of capacitors through stator and rotor electromagnet coils when the electromagnets are in alignment. The capacitors are charged from batteries by a switching mechanism, and are discharged across spark gaps set to achieve the discharge of the capacitor charge voltage through the electromagnetic coils when the gaps and predetermined rotor and stator electromagnet pairs are in alignment.

Exemplary embodiments of the invention are herein illustrated and described. These exemplary illustrations and description should not be construed as limiting the invention to the embodiments shown, because those

skilled in the arts appertaining to the invention may conceive of other embodiments in the light of the description within the ambit of the appended claims.

#### BREIF DESCRIPTION OF THE DRAWINGS

FIG. 1 is an explanatory schematic diagram of a capacitor charging and discharging circuit utilized in the present invention;

FIG. 2 is a block diagram of an exemplary engine system according to the invention;

FIG. 3 is a perspective view of a typical engine system according to the invention, coupled to an automotive transmission;

FIG. 4 is an axial sectional view taken at line 4—4 in FIG. 3;

FIG. 5 is a sectional view taken at line 5—5 in FIG. 4;

FIGS. 6 and 7 are fragmentary sectional views, corresponding to a portion of FIG. 5, illustrating successive advanced positions of the engine rotor therein;

FIG. 8 is an exploded perspective view of the rotor and stator of the engine of FIGS. 3 and 4;

FIG. 9 is a cross-sectional view taken at line 9—9 of FIG. 4;

FIG. 10 is a partial sectional view, similar to the view of FIG. 9, illustrating a different configuration of electromagnets in another engine embodiment of the invention;

FIG. 11 is a sectional view taken at line 11—11 in FIG. 3, illustrating the control head or novel speed change controlling system of the engine;

FIG. 12 is a sectional view, taken at line 12—12 in FIG. 11, showing a clutch plate utilized in the speed change control system of FIG. 11;

FIG. 13 is a fragmentary view, taken at line 13—13 in FIG. 12;

FIG. 14 is a sectional view, taken at line 14—14 in FIG. 11, showing a clutch plate which cooperates with the clutch plate of FIG. 12;

FIG. 15 is a fragmentary sectional view taken at line 15—15 of FIG. 13;

FIG. 16 is a perspective view of electromagnets utilized in the present invention;

FIG. 17 is a schematic diagram showing cooperating mechanical and electrical features of the programmer portion of the invention;

FIG. 18 is an electrical schematic diagram of an engine according to the invention, showing the electrical relationships of the electromagnetic components embodying a new principle of the invention; and

FIG. 19 is a developed view, taken at line 19—19 of FIG. 11, showing the locations of displaced spark gap elements of the speed changing mechanism of an engine according to the invention.

#### DESCRIPTION OF THE PREFERRED EMBODIMENT

As hereinbefore mentioned, the basic principle of operation of the engine of the invention is the discharge of a capacitor, across a spark gap through an inductor. When a pair of inductors is used, and the respective magnetic cores thereof are arranged opposite and another in magnetic polarity repulsion relation, the discharge through them causes the cores to repel each other with considerable force.

Referring to the electrical schematic diagram of FIG. 1, a battery 10 energizes a pulse-producing vibrator

mechanism 16, which may be of the magnetic type incorporating an armature 15 moving between contacts 13 and 14, or of the transistor type (not shown) with which a high frequency bipolar pulsed output is produced in primary 17 of transformer 20. The pulse amplitude is stepped-up in secondary 19 of transformer 20. Wave form 19a represents the bidirectional or bipolar pulsed output. A diode rectifier 21 produces a unidirectional pulse train, as indicated at 21a, to charge capacitor 26. A delay coil 23 is connected in series with the unipolar pulsed output to capacitor 26. Successive unidirectional pulses of wave 21a charge capacitor 26 to a high level, as indicated at 26a, until the voltage amplitude at point A reaches the breakdown potential of spark gap 30. At the breakdown of spark gap 30, capacitor 26 discharges across the arc created through the inductor coil 28. A current pulse is produced which magnetizes core 28a. Simultaneously, another substantially identical charging system 32 produces a discharge through inductor 27 across spark gap 29 to magnetize core 27a. Cores 28a, 27a are wound with coils 28, 27 so that their magnetic polarities are the same. As the cores 27a, 28a confront one another, they tend to fly apart when the discharge occurs through coils 27 and 28 because of repulsion of identical magnetic poles, as indicated by arrow 31. If core 28a is fixed or stationary and core 27a is movable, then core 27a may have tools 33 attached to it to perform work when the capacitor discharges.

Referring to FIGS. 1 and 2, a d-c electrical source or battery 10 energizes pulsators 36 (including at least two vibrators 16 as previously described) when switch 11 between the battery 10 and pulsator 36 is closed, to apply relatively high frequency pulses to the primaries of transformers 20. The secondaries of transformers 20 are step-up windings which apply bipolar pulses, such as pulses 19a (FIG. 1) to the diodes in converter 38. The rectified unidirectional pulsating output of each of the diodes in converter 38 is passed through delay coils 23, 24, thus forming a harness 37 wound about the case of the engine, as hereinafter described, which is believed to provide a static floating flux field. The outputs from delay lines 37 drive respective capacitors in banks 39 to charge the capacitors therein to a relatively high charge potential. A programmer and rotor and stator magnet control array 40, 41, 42 is formed by spark gaps positioned, as hereinafter described, so that at predetermined positions of the rotor during rotation of the engine, as hereinafter described, selected capacitors of capacitor banks 39 will discharge across the spark gaps through the rotor and stator electromagnets 43, 44. The converters 38, magnetic harness 37, capacitor banks 39, programmer 40, and controls 41, 42 from a series circuit path across the secondaries of transformers 20 to the ground, or point of reference potential, 45. The capacitor banks 39 are discharged across the spark gaps of programmer 40 (the rotor and stator magnet controls 41, 42). The discharge occurs through the coils of stator and rotor electromagnets 43, 44 to ground 45. Stator and rotor electromagnets are similar to those shown at 27, 27a, 28, 28a in FIG. 1.

The discharge through the coils of stator and rotor electromagnets 43, 44 is accompanied by a discharge overshoot or return pulse, the output of which is applied in an appropriate polarity to a secondary battery 10a to store this excess energy. The overshoot pulse returns to battery 10a because after discharge the only

path open is that to battery 10a, since the gaps in 40, 41 and 42 have broken down, because the capacitors in banks 39 are discharged and have not yet recovered the high voltage charge from the high frequency pulsers 36 and converter rectifier units 38.

In the event of a misfire in the programmer control circuits 40, 41, 42, the capacitors are discharged through a rotor safety discharge circuit 46 and returned to batteries 10-10a, adding to their capacity. The circuit 46 is connected between the capacitor banks 39 and batteries 10, 10a.

Referring to FIG. 3, a motor or engine 49 according to the present invention is shown connected with an automotive transmission 48. The transmission 48 represents one of many forms of loads to which the engine may be applied. A motor housing 50 encases the operating mechanism hereinafter described. The programmer 40 is axially mounted at one end of this housing. Through apertures 51, 52 a belt 53 couples to a pulley 57 (not shown in this view) and to an alternator 54 attached to housing 50. A pulley 55 on the alternator has two grooves, one for belt 53 to the drive pulley 58 on the shaft (not shown) of the engine 49, and the other for a belt 58 coupled to a pulley 59 on a pump 60 attached to housing 50. A terminal box 61 on the housing interconnects means between the battery assembly 62 and motor 49 via cables 63 and 64.

An intake 65 for air is coupled to pump 60 via piping 68, 69 and from pump 60 via tubing or piping 66, 70 to the interior of housing 50 via coupling flanges 67 and 71. The air flow tends to cool the engine, and the air may preferably be maintained at a constant temperature and humidity so that a constant spark gap discharge condition is maintained. A clutch mechanism 80 is provided on programmer 40.

Referring to FIGS. 4, 5 and 9, rotor 81 has spider assemblies 83, 84 with three electromagnet coil assembly sets mounted thereon, two of which are shown in FIG. 4, on 85 at 85a and 85b, and on 86 at 86a and 86b. One of the third electromagnet coil assemblies, designated 87a, is shown in FIG. 5, viewed from the shaft end. As more clearly shown in the perspective view of FIG. 8, a third spider assembly 88 provides added rigidity and a central support for the rotor mechanism on shaft 81.

The electromagnet sets 85a and 85b, 86a and 86b, 87a and 87b, disposed on rotor 81 and spiders 83, 84, and 88 each comprise pairs of front units 85a, 86a, 87a and pairs of rear units 85b, 86b, 87b. Each pair consists of a major electromagnet and a minor electromagnet, as hereinafter described, which are embedded in an insulating material 90, which insulates the electromagnet coil assemblies from one another and secures the electromagnets rigidly in place on the spider/rotor cage 81, 83, 84, 88.

The interior wall 98 of housing 50 is coated with an electrically insulating material 99 in which are embedded electromagnet coils, as hereinafter described, and the interiors of end plates 100, 101 of the housing 50. On the insulating surface 98 of housing 50 is mounted a series of stator electromagnet pairs 104a, identical with electromagnet pairs 85a, 86a, 87a, etc. Electromagnet pairs such as 104a or 105a are disposed every 40° about the interior of housing 50 to form a stator which cooperates with the rotor 81-88. An air gap 110 of very close tolerance is defined between the rotor and stator electromagnets, and air from pump 65 flows through this gap.

As shown in FIG. 8, the electromagnet assemblies, such as 85 through 87, of the rotor and magnet assemblies, such as 104a in the stator are so embedded in their respective insulative plastic carriers (rotor and stator) that they are smoothly rounded in a concave contour for the stator, and in a convex contour on the rotor to permit smooth and continuous rotation of rotor 81 in stator housing 50. The air gap 110 is uniform at all positions of any rotor element within the stator assembly, as is clearly shown in FIG. 16.

The rotor 81 and spiders 83, 84, 88 are rigidly mounted on a shaft 111 journaled in bearing assemblies 112, 113 which are of conventional type, for easy rotation of the rotor on shaft 111 within housing 50.

Around the central outer surface of housing 50 are wound a number of turns of wire 23, 24 to provide a static flux coil 114 as hereinbefore described, which is a delay line, as previously described.

FIGS. 5, 6, 7 and 9 are cross-sectional views of the rotor assembly 81-88, arranged to show the positioning and alignment of the rotor and stator electromagnet coil assemblies at successive stages of the rotation of rotor 81-88 through a portion of a cycle of operation thereof. For example, in FIG. 5 the rotor assembly 81-88 is shown so positioned that a minor rotor electromagnet assembly 91 is aligned with a minor stator electromagnet assembly 117.

As shown in further detail in FIG. 16, minor electromagnet assembly 117 consists of an iron core 118, grooved so that there may be wound thereabout a coil of wire 119. Core 118 is the same in stator electromagnet 117 as it is in rotor electromagnet 91.

As a position 13½° to the right of rotor electromagnet 91, as viewed in FIGS. 5 and 16, there is a second or major rotor electromagnet 121 which has a winding 123 about its core 122. The electromagnets 91, 121 are the pair 85a of FIGS. 4 and 8.

At a position 13½° to the left of stator electromagnet 117, as viewed in FIG. 5, there is a second or major stator electromagnet 120 whose core 122 is of the same configuration as core 122 of rotor electromagnet 121. A winding 123 about core 122 of electromagnet 120 is of the same character as winding 123 on electromagnet 121.

Electromagnet assembly pair 85a on the rotor is identical in configuration with that of the electromagnet stator assembly pair 104a except for the position reversal of the elements 117-120 and 91-121 of the respective pairs.

There are nine pairs of electromagnets 120-117 (104a) disposed at 40° intervals about the interior of housing 50. The center line of core 122 of electromagnet 120 is positioned 13½° to the left of the center line of the core 118 of electromagnet 117. Three pairs of electromagnets 85a, 86a, 87a are provided on rotor assembly 81-88 as shown in FIG. 5.

Other combinations are possible, but the number of electromagnets in the rotor should always be an integral fraction of the number of electromagnets in the stator. As shown in FIG. 8, for the rotor assembly 85a, 85b, there are three of each of the front and back pairs of electromagnetic assemblies. Similarly, as shown in FIGS. 4 and 8, there are nine front and back pairs of electromagnets in the stator such as 104a and 104b.

In order to best understand the operation of the rotor 81-88 rotating within the stator housing 50 of an engine according to this invention, the positions of rotor

electromagnets 91 and stator electromagnets 117 are initially exactly in line at the  $13\frac{1}{2}^\circ$  peripheral starting position marked on the vertical center line of FIG. 5. The winding direction of the coils of these magnets is such that a d-c current through the coils 119 will produce a particular identical magnetic polarity on each of the juxtaposed surfaces 125 of magnet 117, and 126 of magnet 91, (FIG. 5). FIGS. 16 and 6 illustrate the next step in the motion wherein the two major electromagnets, 120 in the stator and 121 in the rotor, are in alignment.

When the d-c discharges from the appropriate capacitors in banks 39 occur simultaneously across spark gaps through the coils 119 of electromagnets 117 and 91, at the instant of their alignment, their cores 118 will repel one another to cause rotor assembly 81-88 to rotate clockwise in the direction indicated by arrow 127. The system does not move in the reverse direction because it has been started in the clockwise direction by the alternator motor 54 shown in FIG. 3, or by some other starter means. If started counterclockwise, the rotor will continue to move counterclockwise.

As hereinbefore noted, the discharge of any capacitor occurs over a very short interval across its associated spark gap, and the resulting magnetic repulsion action imparts motion to the rotor. The discharge event occurs when electromagnets 117 and 91 are in alignment. As shown in FIG. 5, rotor electromagnet 91a is aligned with stator electromagnet 117c, and rotor electromagnet 91b is aligned with stator electromagnet 117e at the same time that similar electromagnets 117 and 91 are aligned. A discharge occurs through all six of these electromagnets simultaneously (that is, 117, 91, 117c, 91a, 117e and 91b). A capacitor and a spark gap are required for each coil of each electromagnet. Where, as in the assembly shown in FIG. 8, front and back pairs are used, both the axial in-line front and back coils are energized simultaneously by the discharge from a single capacitor or from a bank of parallel capacitors such as 25, 26 (FIG. 1). Although FIGS. 4 and 8 indicate the use of front and back electromagnets, it should be evident that only a single electromagnet in any stator position and a corresponding single electromagnet in the rotor position, may be utilized to accomplish the repulsion action of the rotor with respect to the stator. As stated, each electromagnet requires a discharge from a single capacitor or capacitor bank across a spark gap for it to be energized, and the magnetic polarity of the juxtaposed magnetic core faces must be the same, in order to effect the repulsive action to produce the rotary motion.

Referring to FIGS. 5 and 6, the repulsion action causes the rotor to move  $13\frac{1}{2}^\circ$  clockwise, while electromagnets 91, 91a and 91b move away from electromagnets 117, 117c and 117e to bring electromagnets 121, 121a and 121b into respective alignment with electromagnets 120a, 120d and 120f. At this time, a capacitor discharge across a spark-gap into their coils 123 occurs, thus moving the rotor. Another  $13\frac{1}{2}^\circ$  ahead, as shown in FIG. 7, major electromagnets 121, 121a and 121b come into alignment with minor electromagnets 117a, 117d and 117f, at which time a discharge occurs to repeat the repulsion action, this action continuing as long as d-c power is applied to the system to charge the capacitors in the capacitor banks.

FIG. 18 further illustrates the sequencing of the capacitor discharges across appropriate spark gap termi-

nal pairs. Nine single stator coils and three single rotor coils are shown with their respective interconnections with the spark gaps and capacitors with which they are associated for discharge. When the appropriate spark gap terminals are aligned, at the points in the positioning of the rotor assembly for most effective repulsion action of juxtaposed electromagnet cores, the discharge of the appropriate charged capacitors across the associated spark gap occurs through the respective coils. The capacitors are discharged in sets of three through sets of three coils at each discharge position, as the rotor moves through the rotor positions. In FIG. 18, the rotor electromagnets are positioned linearly, rather than on a circular base, to show the electrical action of an electric engine according to the invention. These motor electromagnets 201, 202, and 203 are aligned with stator electromagnets 213, 214 and 215 at  $0^\circ$ ,  $120^\circ$  and  $450^\circ$  respectively. The stator electromagnets are correspondingly shown in a linear schematic as if rolled out of the stator assembly and laid side by side. For clarity of description, the capacitors associated with the rotor operation 207, 208, 209 and 246, 247, 248, 249, 282 and 283 are arranged in vertical alignment with the respective positions of the rotor coils 201, 202, 203 as they move from left to right, this corresponding to clockwise rotation of the rotor. The stator coils 213, 214, 215, 260, 261, 262, 263, 264, 265, 266, etc. and capacitor combinations are arranged side by side, again to facilitate description.

An insulative disc 236 (shown in FIG. 17 as a disc, but opened out linearly in FIG. 18) has mounted thereon three gap terminal blocks 222, 225 and 228. Each block is rectangularly U-shaped, and each interconnects two terminals with the base of the U. Block 222 has terminals 222a and 222b, block 225 has terminals 225a and 225b, and block 228 has terminals 228c and 228d. When insulative disc 230 is part of the rotor, as indicated by mechanical linkage 290, it can be seen that terminal U 222 creates a pair of gaps with gap terminals 223 and 224, respectively. Thus, when the voltage on capacitor 216 from charging circuit 219 is of a value which will arc over the air spaces between 222a and 223, and between 222b and 224, the capacitor 216 will discharge into the coil of electromagnet 213 to ground. Similarly gap terminal U 225 forms a dual spark gap with gap terminals 226 and 227 to result in arc-over when the voltage on capacitor 217, charged by charging circuit 220, discharges into the coil of electromagnet 214. Also, U-gap terminal 228 with terminals 228c and 228d, creates a spark gap with terminals 229 and 230 to discharge capacitor 218, charged by charging circuit 221, into coil 215. At the same time, rotor coils, 201, 202 and 203 across gaps 201a-204, 202b-205 and 203c-206 each receives a discharge from respective capacitors 207, 208, and 209.

When the electromagnet coils 213, 214, 215 and 201, 202, 203 are energized, the repulsion action causes the rotor assembly to move to position 2 where a new simultaneous group of discharges occurs into rotor coils 201, 202, and 203 from capacitors 246, 248, and 282 across gaps 201a-240, 202b-242 and 203c-244. Simultaneously, because gap-U-elements 222, 225 and 228 have also moved to position 2 with the rotor assembly, capacitor 261 is discharged through electromagnet coil 260, capacitor 265 is discharged through electromagnet coil 264, and capacitor 269 is discharged through electromagnet coil 268 in align-

ment with position 2 of the rotor electromagnet coils, thus to cause the rotor electromagnets to move to position 3 where the discharge pattern is repeated now with capacitors 247, 249 and 283 discharging through the rotor electromagnet coils 201, 202, 203, and the capacitors 263, 267 and 281 discharging respectively through stator electromagnet coils 262, 266 and 280.

After each discharge the charging circuits 219-221 and 272-277 for the stator capacitors, and 210-212 and 284-289 for the rotor capacitors, are operated continuously from a battery source, as described earlier with reference to FIG. 1, to constantly recharge the capacitors to which each is connected. Those versed in the art will appreciate that, as each capacitor discharges across an associated spark gap, the resulting drop in potential across the gap renders the gap an open circuit until such time as the capacitor can recharge to the arc-over level of the gap. This recharge to a discharge potential occurs before a rotor element arrives at the next position in question.

The mechanical schematic diagram of FIG. 17 further clarifies the operation of the spark-gap discharge programming system. A forward disc 236 of an electrically insulative material, has thereon the set of U-shaped gap terminal connectors previously described. These are positioned at 0°, 120° and 240° respectively. In FIG. 17, schematic representations of the position of the coil and capacitor arrangements at the start of a cycle are shown to correspond to the description hereinabove with reference to FIG. 18. Accordingly, the coil and capacitor combinations 213/216, 214/217, and 215/218 are shown connected with their gap terminals, respectively, 223/224, 226/227 and 229/230. On the rotor coil and capacitor connection three separate discs 291, 292 and 293 are shown, each with a single gap terminal. The discs 291-293 are rotated so as to position their respective gap terminals 201a, 202b and 203c at 120° increments, with the 0° position corresponding to the 0° position of U-gap terminal 222 on disc 230.

Representative gap terminals are shown about the peripheries of discs 230, 291-293 to clearly indicate how, as the discs turn in unison, the gap alignments correspond so that three rotor coil/capacitor positions always line up with three stator coil/capacitors at 120° intervals about the rotary path, producing an alignment every 40°, there being nine stator coils. Thus there are three simultaneous discharges into stator coils and three into rotor coils at each 40° position. Nine positions displaced 40° apart provide a total of 27 discharge points for capacitors into the rotor coils and 27 discharge points for capacitors into the stator coils in one revolution.

It will be understood that, as illustrated in FIGS. 17 and 18, nine individual electromagnet coils are shown in the stator and three in the rotor, in order to show in its simplest form how the three rotor electromagnets are stepped forward from alignment with three of the stator electromagnets, when the appropriate spark gaps are in alignment, to effect the discharge of capacitors through juxtaposed pairs of rotor/stator electromagnets. The repulsion moves the rotor electromagnet from the stator electromagnet to the next alignment position advanced at an arc of 40° from the preceding alignment position. In the interval until another rotor electromagnet, 120° removed, is aligned with the stator electromagnet that had just been excited, the associ-

ated capacitor is recharged to a potential which will cause the spark gap to break down to produce another discharge of this capacitor on the next revolution. Thus the rotor moves from one position to the next, with capacitor discharges occurring each 40° of rotation, a total of nine per revolution. It should be obvious that, with other rotor/stator combinations, the number of electromagnet coincidences and spark-gap discharges will vary. For example, with the coil pairs shown in FIGS. 4 through 8, a total of 27 discharges will occur. Although there are 18 stator electromagnets and three rotor electromagnets, the discharge pattern is determined by the specific spark gap arrangement.

The rotor/stator configuration of FIGS. 5 and 8, involving the major and minor pairs of electromagnets such as 85a and 104a (the terms "minor" and "major" referring to the difference in size of the elements), include nine pairs of electromagnets in the stator, such as 104a, with three electromagnet pairs of the rotor, such as 85a. Because of the 13½° separation between the major and minor electromagnets in the rotor pair 85a, with the same separation of minor and major electromagnets of the stator pair 104a, the sequence of rotation and discharge described above, with respect to the illustrative example of FIG. 5, involves the following:

1. A minor element 117 of stator pair 104a is aligned with the minor element 91 of rotor pair 85a. On the discharge, this moves the rotor ahead 13½°.

2. The major rotor element 122 of the pair 85a now is aligned with the major stator element 120b of the next stator electromagnet pair, in the stator array as shown in FIG. 6. On the discharge, the rotor moves ahead 13½°.

3. This brings the minor rotor electromagnet 91 into alignment with the major stator electromagnet 120b of pair 104d, and the major electromagnet 122 (just discharged) of pair 85a into alignment with minor electromagnet 117b of pair 104d, and the rotor spark gap elements into alignment with a different position of gap elements connected with capacitors not discharged in the previous position of the rotor. It should be remembered at this point that it is the positioning of a rotatable spark gap array, similar to that illustrated in FIGS. 17 and 18, which controls the time of discharge of capacitors connected to these gap terminals. Therefore, any electromagnet can be energized twice successively from separate capacitors as the rotor brings appropriate gap terminals into alignment with the coil terminals of a particular electromagnet.

Thus, although major electromagnet 120b of pair 104d has just been energized as described above, it can now be energized again along with minor rotor electromagnet 91 in step 3, because the rotor moved to a new set of terminals of the spark gap arrays connected with capacitors not yet discharged. These capacitors now discharge through rotor electromagnet 91 and stator electromagnet 120b, causing rotor to move ahead another 13½°, thus again aligning two minor electromagnets again, these being 117b of stator pair 104d and 91 of rotor pair 85a. The rotor has now moved 40° since step 1 above. The sequence is repeated, and it is to be noted that at each 13½° step, the discharges rotate the rotor another 13½°. There are 27 steps per revolution with nine stator coil pairs. The discharge sequence is not uniform, as is shown in Table I. In the stator, three major electromagnets 120° apart are energized twice in sequence followed by a hiatus of one step while three